

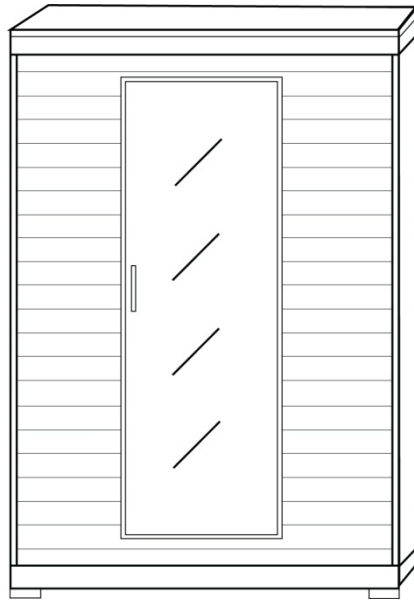

# HeatWave Sauna

## 1 PERSON & 2 PERSON SAUNAS

AVAILABLE WITH CERAMIC OR CARBON HEATERS



## BEFORE YOU BEGIN

### CHECK ELECTRICAL REQUIREMENTS



1 and 2 person saunas require standard **15 amp** electrical power.

### CHOOSING A LOCATION:

The sauna must be placed **INDOORS**, on a fairly level surface. Area must be dry, as moisture will cause damage to the sauna.

### YOU WILL NEED

- Ladder
- Power Drill *(optional)*
- Stocking feet *(dark soled shoes can stain the unfinished wood surface of the sauna interior)*

### CARTON CONTENTS

Open all cartons and inspect to ensure that no parts are missing. Use the Carton Contents listing and diagram on the following page to familiarize yourself with the parts of the sauna.

### INSTRUCTIONS

Read through all assembly steps and safety information in this manual before beginning sauna installation.

### 2 PERSON ASSEMBLY



# Carton Breakdown – 1 & 2 Person Saunas

CARTON 1:		
KEY #	DESCRIPTION	QTY
1	Top Panel	1
2	Top Maintenance Panel	1
3	Bottom Panel	1
4	Bench Top	1
5	Bench Front	1
6	Magazine Rack	1
7	Towel Rack**	1
--	Back Rest <i>(1 person =1 backrest; 2 person = 2 backrests)</i>	1 or 2
8	Radio	1
RADIO / ACCESSORY HOUSING BOX*		
9	Wooden Radio Housing Box	1
10	Oxygen Ionizer**	1
11	Color Therapy Bulb**	1
12	Door Handle Set	1
--	Hardware bag <i>(extra hardware is included)</i>	1
CARTON 2:		
KEY #	DESCRIPTION	QTY
13	Front Panel w/door	1
14	Back Panel	1
15	Left Side Panel	1
16	Right Side Panel	1

\* Contains the wood box, ionizer, therapy light bulb, remote, hardware bag & door handles

\*\*These items may only be available on the 2 person sauna models

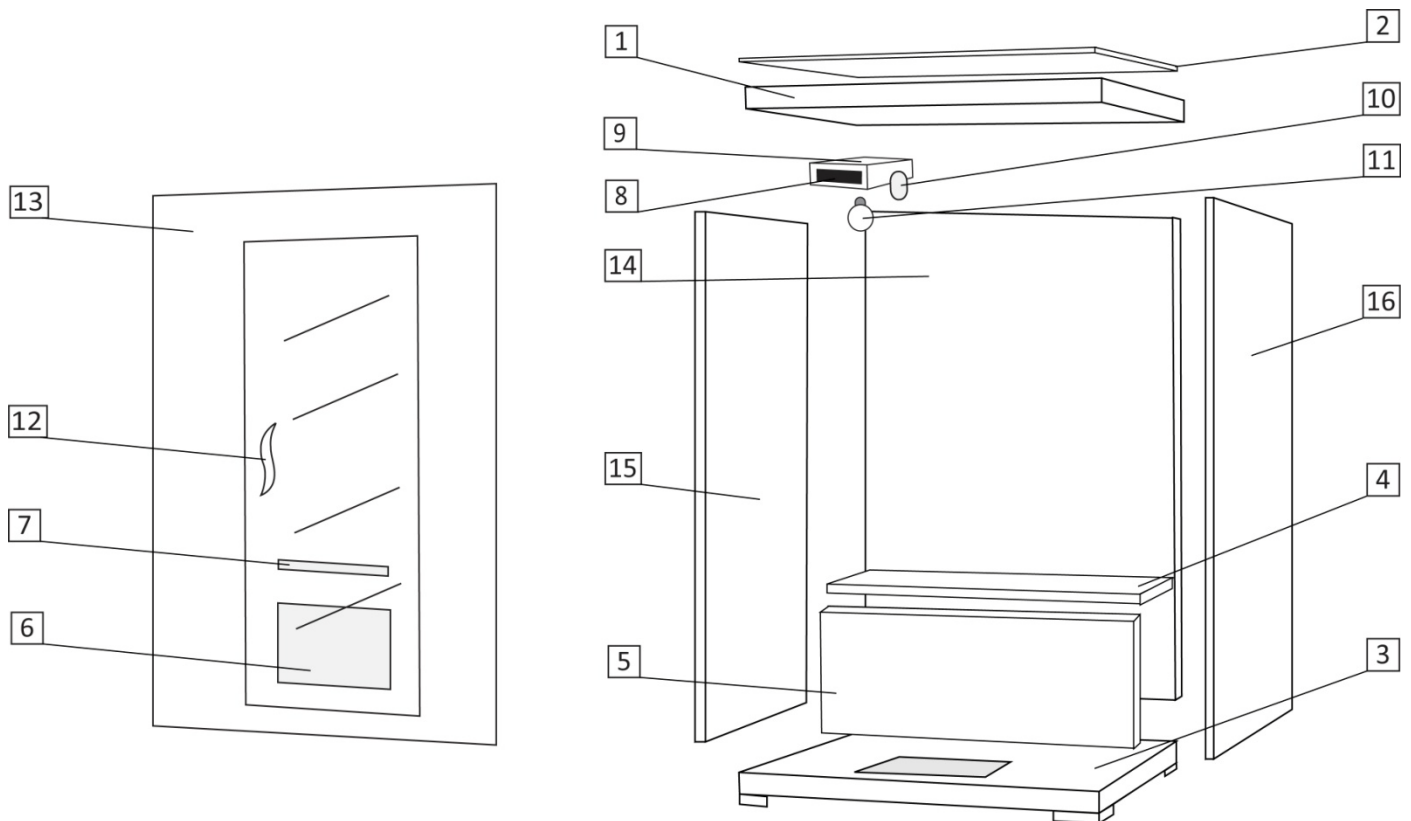

# Sauna Assembly

\*NOTE: YOUR SAUNA MODEL MAY VARY FROM THE IMAGES BELOW.

- Locate the **BOTTOM PANEL (3)** and position it approximately where you want your sauna to be located, leaving enough space around all sides for assembly.

*Note: The steps outlined below are the recommended order for installation of sauna panels, due to the manner in which the panels fit together. You may install them in a different order if desired. Be sure each panel locks securely in place before moving on to the next panel.*

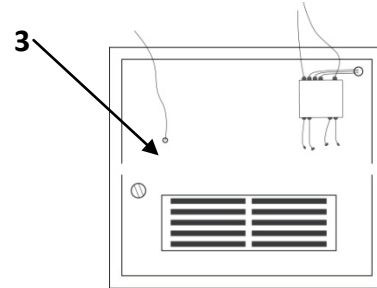

- Locate the **FRONT PANEL WITH DOOR (13)** and place it in the grooves on the front side of the bottom panel. Align with slats in floor where benches will be positioned.

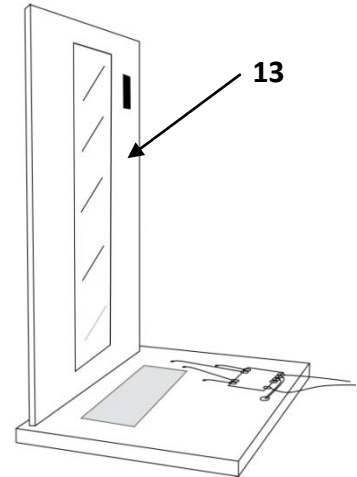

- While 1 person holds the **FRONT PANEL (13)** to stabilize it, the other person should locate the **LEFT SIDE PANEL (15)** and place it in the grooves along the left side of the bottom panel. Insert the screws on side panel into the corresponding holes on the front panel, shift panels to fasten together securely and lock into place.

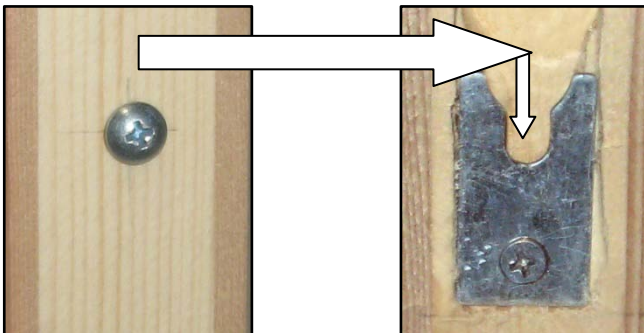

- Locate the RIGHT SIDE PANEL (16), place in grooves along the right side of the bottom panel. Insert the screws on side panel into the corresponding holes on the front panel, shift panels to fasten together securely and lock into place.

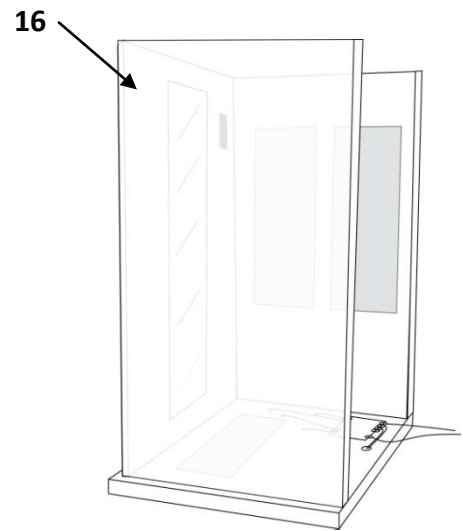

- Remove the temporary wood door braces from the outside of the glass door (a). There is 1 located at top of door and 1 located at bottom of the door.  
*These keep the glass door securely in place during shipping.*

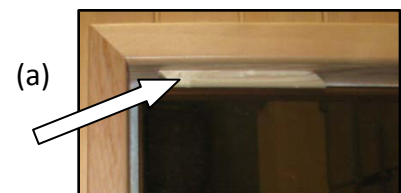

- Install the DOOR HANDLES (12) – the unfinished wood pieces go inside; finished wood pieces go on the outside. (b)
- Secure the TOWEL RACK (7) to the inside of the door, using the pre-drilled holes in the middle position. Secure the MAGAZINE RACK (6) to the inside of the glass door, using the pre-drilled holes in the bottom position. (c)  
*NOTE: Not all sauna models are equipped with these accessories*

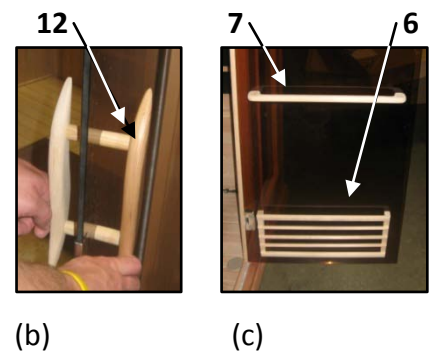

- Connect lettered plugs on floor to corresponding plugs from the side walls.
- Install BENCH FRONT (5).
- Match lettered plug in floor to corresponding plug on bench front, twist the cord cover to secure in place. (d)



- Install the BACK PANEL (14).

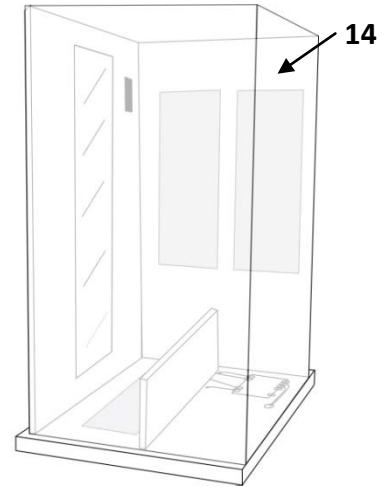

- Connect plug from BACK PANEL (14). Feed power cord through wall port on BACK PANEL (14) - rotate the port to allow cord to be fed through. (e)
- Check to be sure all connections are properly secured with their corresponding lettered plugs.
- Install BENCH TOP (4).

(e)

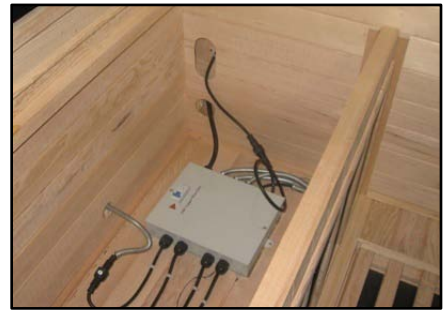

- Remove TOP MAINTENANCE PANEL (2) from TOP PANEL (1).
- Install TOP PANEL (1) on top of sauna

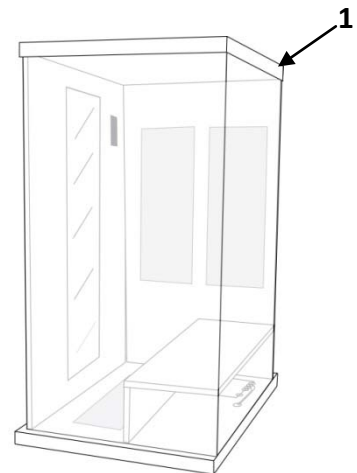

## TOP PANEL

- Align TOP PANEL (1) on top of sauna, feed connectors through the guide holes in the front and back of the top panel.
- Using a ladder, connect the 2 circuit connectors located in the front area of the top (f).
- Connect the plug located in the back corner of the top (g).
- Replace TOP MAINTENANCE PANEL (2) – panel can be secured with screws if desired, but is not necessary.

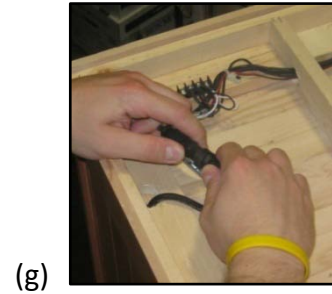
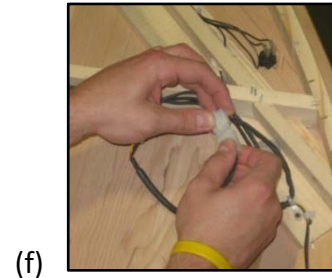

## ACCESSORIES

- Locate the RADIO (8) and WOOD RADIO HOUSING BOX (9).
- Connect the circuit connector (h)
- Install the RADIO (8) into the front of the HOUSING BOX (9). Plug (2) connectors into the rear of radio (i).
- Feed the ionizer plug through the hole so that it's accessible from the outside of the housing box.
- Secure the housing box to the walls of the sauna with 4 screws (j). May use a power drill if necessary.
- Screw in the COLOR THERAPY LIGHT BULB (11), & add batteries to the light remote to operate. Plug the cord into the IONIZER (10), secure ionizer onto the outside of the radio housing box (k).
- Plug sauna into wall outlet – ***always unplug sauna when it is not in use.***

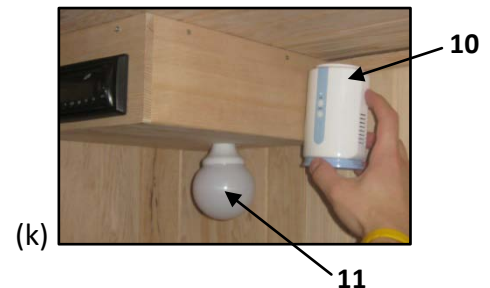
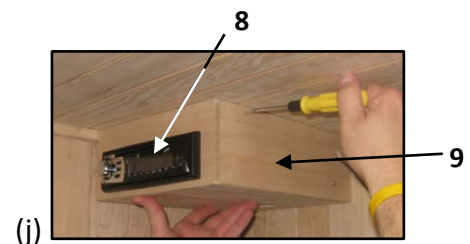
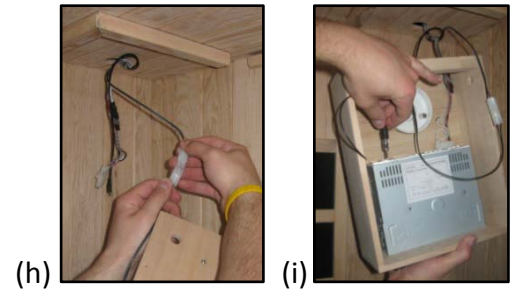

*\*NOTE: Some models may not come with all the accessories described above.*

# Congratulations, assembly of your sauna is now complete!

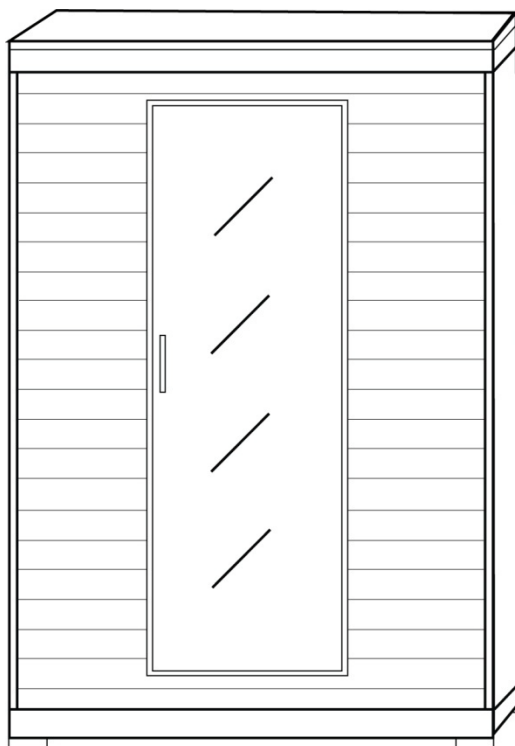

## CONTROL PANEL

- Use the ON/OFF button to turn on the sauna
- When the sauna is turned on, the set temperature is 101°F (40°C)
- Change the temperature by pressing the ▲ or ▼ buttons to increase or decrease the set temperature
- Change the set time by pressing the ▲ or ▼ buttons on the time portion of the control panel
- After 5 seconds, the display flashes the set temperature two times, then displays the current temperature inside the sauna.
- Set temperature can be changed at any time using the ▲ or ▼ buttons.
- Click the °C/°F button to switch the display between Centigrade and Farenheit.
- Buzzer will beep when the time counts down to 0, or when the temperature in the sauna reaches your set temperature.
- After your sauna session, press the ON/OFF button and unplug the sauna's power cable.

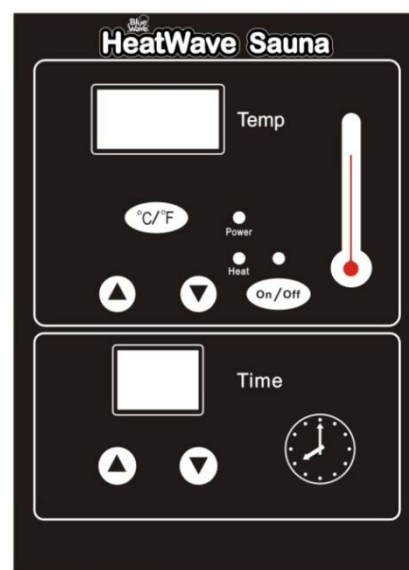

## TIPS FOR USE:

- Prior to initial use, wipe down all surfaces of the unit with a damp cloth.
  - Turn on unit and set to 104° F for one hour. This will ensure that all factory dust is removed or burnt off.
  - Be sure that you are adequately hydrated prior to using your sauna.
  - The floor and ceiling vents may be opened for air circulation.
  - While using your sauna, it is recommended to place towels on the bench seats. This will help absorb perspiration and maintain cleanliness of the sauna.
  - Limit the use of lotions or oils prior to using the sauna; these products can block your pores and limit perspiration, decreasing the effectiveness of your sauna session.
  - For spot treatment of a particular area, position that body part closer to the heater, allowing for deeper heating in that area.
- The warm-up speed of your sauna will depend on the ambient room temperature. If the room temperature is very low, the sauna will take longer to reach the desired temperature.

## RECOMMENDED TEMPERATURE SETTINGS

- 104°F (40°C) – 115°F (46°C): Relaxation and Detoxification
- 116°F (46°C) – 135°F (57°C): Perspiration
- 136°F (57°C) – 150°F (65°C): Heat Therapy \*

\*Heat Therapy level temperatures are recommended for no more than 5 minutes at a time

## CLEANING AND MAINTENANCE

- When cleaning the exterior, use furniture polish or furniture oil.
- Interior wood surfaces are unfinished - do not use furniture polish or oil on the interior surfaces of the sauna.
- Interior surfaces can be wiped down with a damp cloth.
- Use a towel on the benches and under feet to absorb perspiration and keep sauna clean and sanitary.

## DO NOT USE A SAUNA IF YOU HAVE ANY OF THE FOLLOWING CONDITIONS:

- Open wounds
- Severe sunburn
- Under the influence of alcohol or drugs
- Dehydration
- Serious illness of any type
- Joint or muscle injury that occurred within the last 48 hours
- Heatstroke
- People who are weak, suffering from an illness, pregnant women and children under the age of 6 should not use a sauna.

*Children over the age of 6 may use the sauna under the supervision of an adult.*



## **HYPERTHERMIA**

30 minutes or less is the recommended length of time for a single sauna session. Hyperthermia occurs when the internal temperature of the body reaches a level several degrees above the normal body temperature of 98.6° F (37° C). Being properly hydrated, using the sauna for reasonable lengths of time, and being aware of your body's reaction to heat will help prevent hyperthermia. Be aware of the symptoms and dangers of hyperthermia. These include:

- Increase in internal body temperature
- Dizziness, Drowsiness & Lethargy
- Fainting
- Failure to perceive heat
- Failure to recognize the need to exit the sauna
- Physical inability to exit the room
- Unconsciousness

## **WARNING:**

- Consult your doctor before using the sauna if you are pregnant or are under medical care.
- The use of drugs, alcohol or medication is capable of greatly increasing the risk of hyperthermia.
- If you feel uncomfortable, dizzy or sleepy, exit the sauna immediately.
- Supervise children at all times.
- Do not use stay in sauna for longer than the recommended length of time (30 minutes).
- Reduce the risk of fire – do not place combustible material on heater at any time.
- Do not plug any other appliances into the outlet with your sauna.
- Do not store flammable objects or chemical substances near the sauna.
- Do not change the light bulb while sauna is in operation.
- Do not spray the exterior of sauna with water.
- Do not allow water to contact any part of the heating sources, electrical equipment or wiring.
- To prevent scalding or electric shock, do not allow any body part to come in contact with the heating sources, electrical equipment or wiring.
- To prevent damage to the sauna, it is recommended to stop operation for one hour after two continuous hours of use.



### HeatWave Sauna™ Warranty Registration Card

1. HeatWave Saunas™ have a 5-Year Warranty against defects in materials and workmanship. To receive the warranty, the card must be filled out completely and returned. This 5-Year Warranty covers the sauna. The radio in your HeatWave Sauna™ is covered by a limited 1-Year Warranty.
2. Please notify Blue Wave Products in advance of any sauna warranty claim prior to shipping the sauna back. Contact our warranty claim department at [warranty@splashnetxpress.com](mailto:warranty@splashnetxpress.com).
3. If the warranty claim department determines that the item must be returned, it must be returned with a receipt showing date of purchase, purchase price, and the dealer from which the sauna was purchased. **No warranty claim will be honored without a receipt.**
4. The freight on the item when returned must be prepaid.
5. Warranty claims will only be resolved with the repair of the current product or shipment of a replacement product. NO REFUNDS will be given.
6. Improper installation, misuse or damages resulting from acts of nature will render this warranty null and void.
7. This warranty is in lieu of all other warranties expressed or implied and no responsibility is assumed for future damage due to misuse. HeatWave Saunas™ are intended for INDOOR USE ONLY – outdoor installation of the sauna WILL VOID THE WARRANTY. We are not responsible for damage to the sauna due to improper installation or misuse. Additional actions that will void the warranty are: Use of lacquer or paints, placing sauna on non-approved surface, and outdoor applications.

**Surface cracks are not considered defects in material or workmanship, as they are normal characteristics of all wood.**

*To send in this warranty card: Fill out below, detach and mail to the following address:*

**BLUE WAVE PRODUCTS  
1745 Wallace Ave. Suite B  
St. Charles, IL 60174**

HEATWAVE SAUNA™ WARRANTY REGISTRATION FORM

Date Purchased: \_\_\_\_/\_\_\_\_/\_\_\_\_

Purchaser: \_\_\_\_\_

Address: \_\_\_\_\_

City/State/Zip: \_\_\_\_\_

Phone: (    ) \_\_\_\_\_ Email: \_\_\_\_\_

Purchased from: \_\_\_\_\_

Item Number: \_\_\_\_\_ Purchase Price: \_\_\_\_\_