

DO NOT RETURN THIS PRODUCT TO RETAILER



**IN GROUND RESIDENTIAL
ROBOTIC SWIMMING POOL CLEANER**

**OPERATOR'S MANUAL &
TROUBLESHOOTING GUIDE**



TURBOT

Please Read Carefully Before Using Your Pool Cleaner

TABLE OF CONTENTS

Operating Features	3-4
Quick Start Instructions	5
Setting Up Your Cleaner.....	6-7
Floating Handle	6
Setting up the Power Supply	7
Cleaner Start Position	7
Knowing / Using Model Features	8-10
Setting the Power Supply Timer.....	8-9
Using the Remote Control	9
Debris Intake Port Width Selector	10
Variable Intake Port Depth Extensions	10
NeverStuck™ Rollers	10
Power Washing Jet System.....	10
Cleaning Pattern / Directional Guidance Mechanism.....	11
Cleaning Pattern.....	11
Maintaining Your Pool Cleaner	12-17
Cleaning and Changing the Filter Bag	12
Flotation.....	13
Propeller Care	13
Floating Cable Care	14
Scrubbing Brushes Care & Replacement	14
Changing Drive Tracks	15
Changing Drive Belts & Drive Belt Assembly.....	15-16
Cleaner Storage	17
Preparing Your Cleaner for Shipping	17-18
Troubleshooting Guide (Summary).....	19-20
Troubleshooting Guide (In Depth)	21-25



WARNING: Never operate your cleaner when it is not totally submersed in the pool water! Doing so will void warranty and may cause severe damage to motors and require costly repairs!



WARNING: Never allow anyone to swim in the pool while the cleaner is in the pool!



WARNING: Using the Floating Cable to lift the cleaner out of the water will cause severe damage to your cleaner and may result in costly repair!



WARNING: The Power Supply must be at least 12 feet / 4 meters from the pool's edge at all times!



WARNING! A Ground Fault Circuit Interrupter (GFCI) / Residual Current Device (R.C.D), must be installed to protect your electric outlet and to prevent and possible electrical shock!

OPERATING FEATURES

The reference numbers below are used throughout this manual.

Figure 1

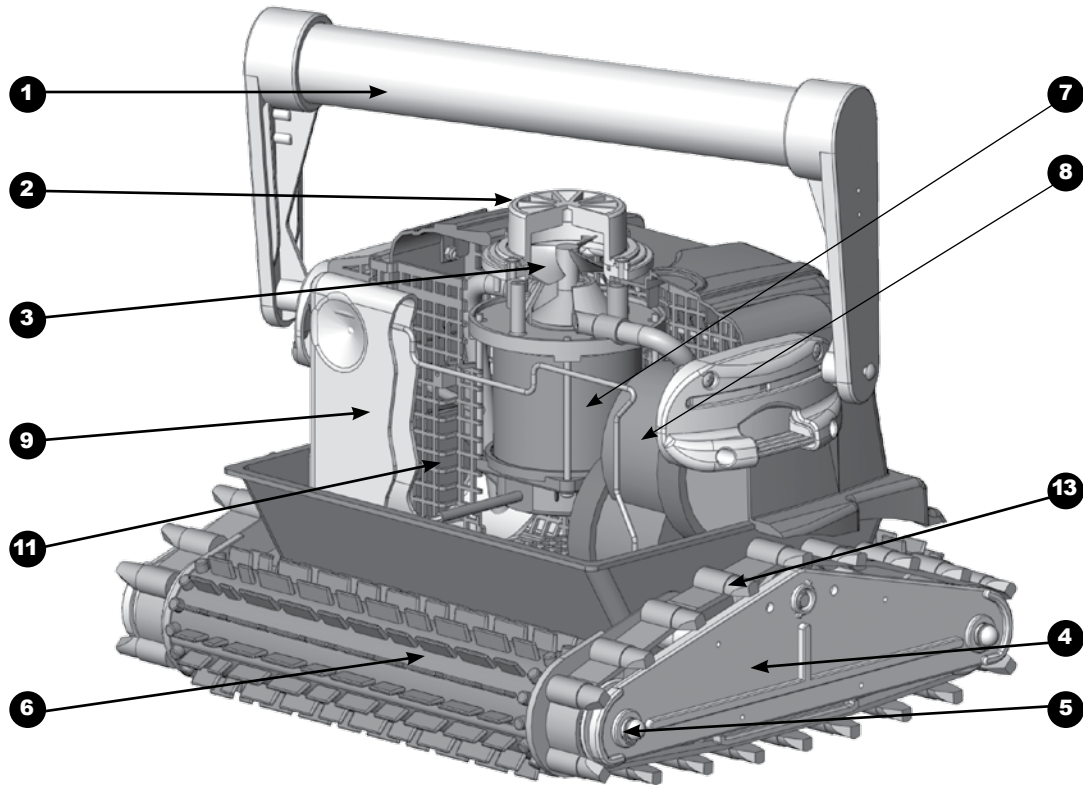

- | | | |
|------------------------------|--------------------------------------|--------------------------------|
| 1. Floating Handle | 6. Brushes | 11. Filter Screen |
| 2. Outlet Top | 7. Pump Motor | 12. Floating Cable (SEE BELOW) |
| 3. Propeller | 8. Drive Motor | 13. G-Tooth™ Drive Track |
| 4. Side Plate | 9. Filter Bag | 14. Wheel Tube |
| 5. Wheel Tube Retaining Ring | 10. Bottom Lid Assembly (SEE PAGE 4) | |

*Cable Guard is an optional item available for purchase separately.

FLOATING CABLE FEATURES

Figure 2

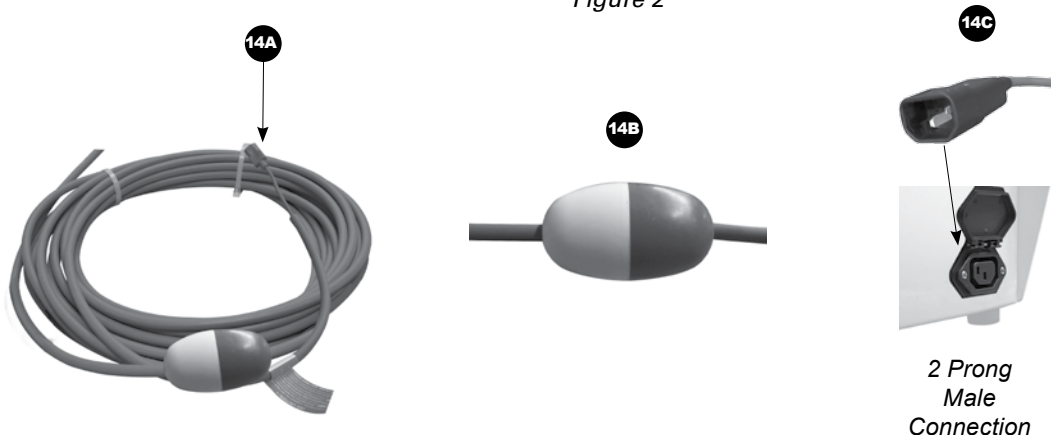

- 14a. Floating Cable
- 14b. Cable Float
- 14c. Cable Float (2 PRONG MALE CONNECTION)

BOTTOM LID ASSEMBLY

Figure 3

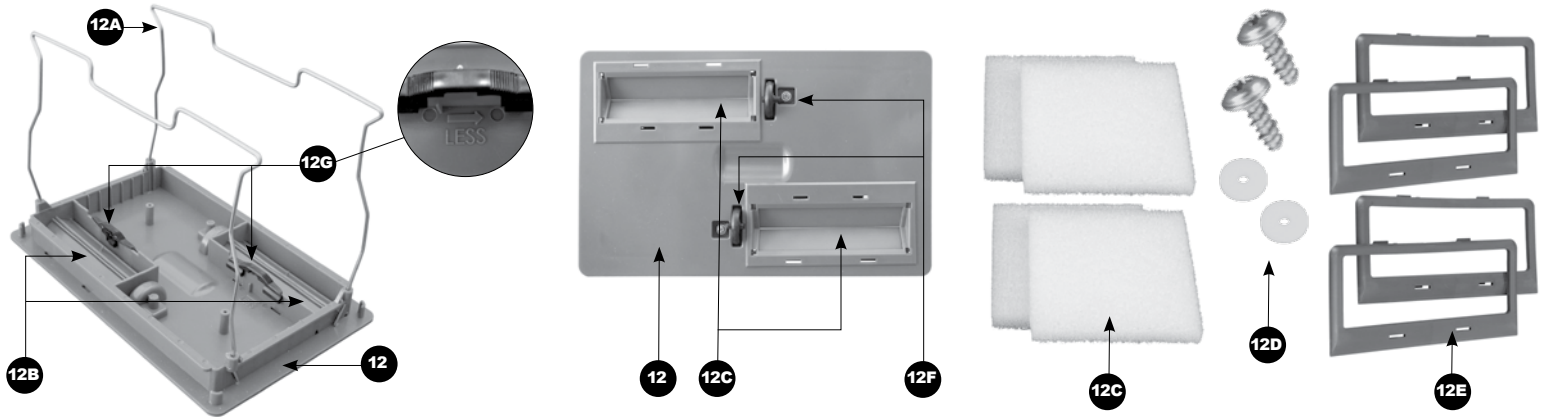

- | | |
|------------------------------|----------------------------------------|
| 12. Bottom Lid | 12d. Float Screw & Washers |
| 12a. Wire Frame Bag Support | 12e. Variable Port Depth Extension |
| 12b. Debris Intake Port Flap | 12f. NeverStuck™ Rollers |
| 12c. Square Floats | 12g. Debris Intake Port Width Selector |

POWER SUPPLY FEATURES

Figure 4
(With Remote Control)

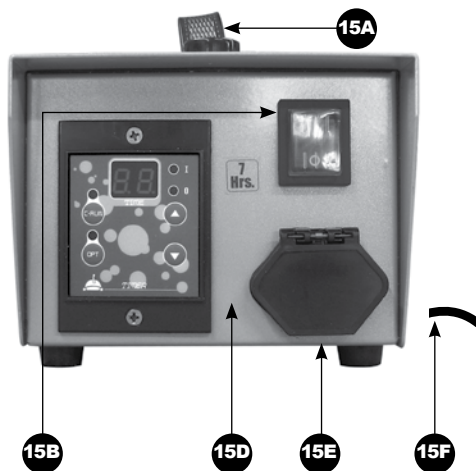

- | |
|-----------------------------|
| 15a. Power Supply Handle |
| 15b. Power Switch - ON/OFF |
| 15c. Fuse Holder* |
| 15d. Power Supply (Housing) |
| 15e. Floating Cable Socket |
| 15f. Power Supply Cable |

* Fuse Holder is located on the back of the Power Supply

SETTING UP YOUR NEW ROBOTIC POOL CLEANER IS AS EASY AS 1, 2, 3!



TIP! To help protect your Floating Cable from potentially getting wrapped around your cleaner's brushes, it is suggested to turn off your pool's filtration system while your cleaner is in operation to reduce the pool's filter circulation effect that may push the Cable against the waterline.

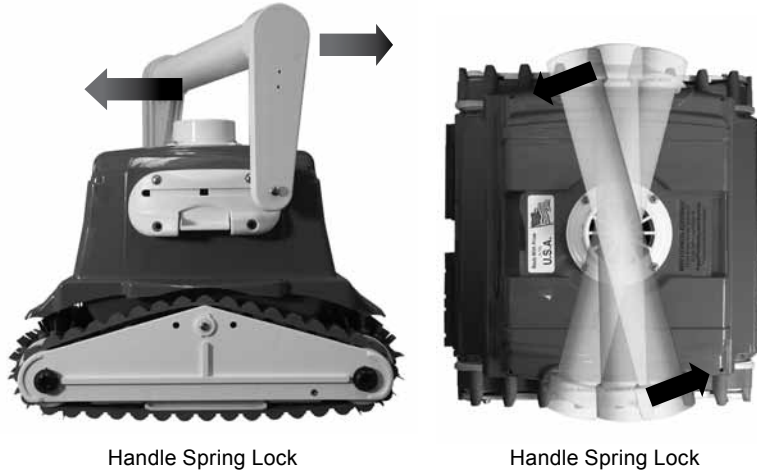

Handle Spring Lock

Handle Spring Lock

Figure 5a

3 Diagonal Positions

Smaller angle allows slower movement when at waterline,
Larger angle provides faster movement.

Figure 5b

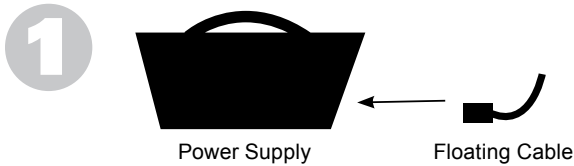

Power Supply

Floating Cable

Make sure that the Power Supply is positioned at the center of the long side of the pool that the cleaner enters at the pool at its midpoint.

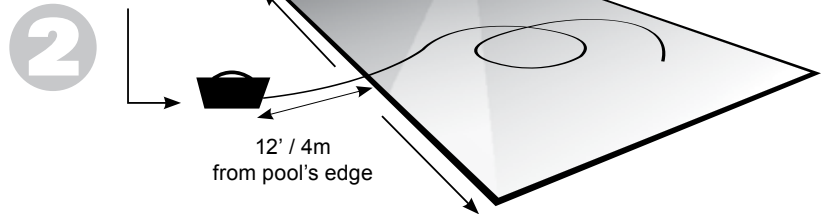

Figure 5c

12' / 4m
from pool's edge



WARNING: The Power Supply must be placed at least 12 feet / 4 meters from the pool's edge!



Figure 5d

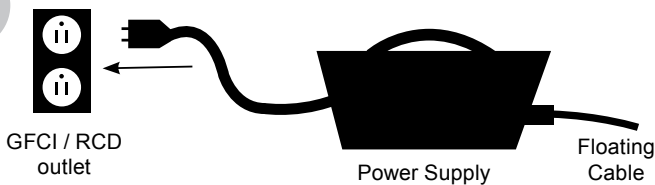

GFCI / RCD
outlet

Power Supply

Floating
Cable

NOTE: It is suggested to unplug the Power Supply when the cleaner is not in use to protect your cleaner's unintentional out-of-water operation due to power surges or accidental pressing of the Power Supply ON / OFF Switch.

NOTE: Your Power Supply features a Safety Reset Button (Page 8; Fig. 7) to prevent unintentional, "out of water" operation due to power surges or accidental pressing of the Power Supply ON / OFF Switch. Press the Switch to ON and then press the Reset Button to start your cleaner.

NOTE: Please consult this operator manual for further instructions on how to set its operating time and automatic shut down.



WARNING: A Ground Fault Circuit Interrupter (GFCI) / Residual Current Device (R.C.D.) must be installed to protect your electric outlet and to prevent any possible electrical shock!

SETTING UP YOUR ROBOTIC POOL CLEANER

1. FLOATING HANDLE

The Floating Handle (Page 5; Fig. 5a) is a flotation device that helps your cleaner climb and is a handle to hold and carry your cleaner. For proper operation of your pool cleaner, the Handle must be locked diagonally* across the top of the cleaner's body.



IMPORTANT: It is helpful to reverse the diagonal Handle direction after every use of your cleaner to protect the Floating Cable (Page 3; Fig. 2) from becoming twisted or kinked and will not limit the cleaning coverage of your cleaner!

To Lock The Floating Handle:

Figure 6

Handle Spring Lock

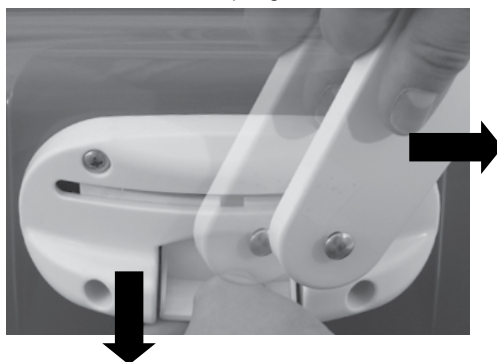

NOTE: Occasionally new cleaner's may require a bit of force in order to slide the Floating Handle into place the first few times until the internal slot becomes smooth.

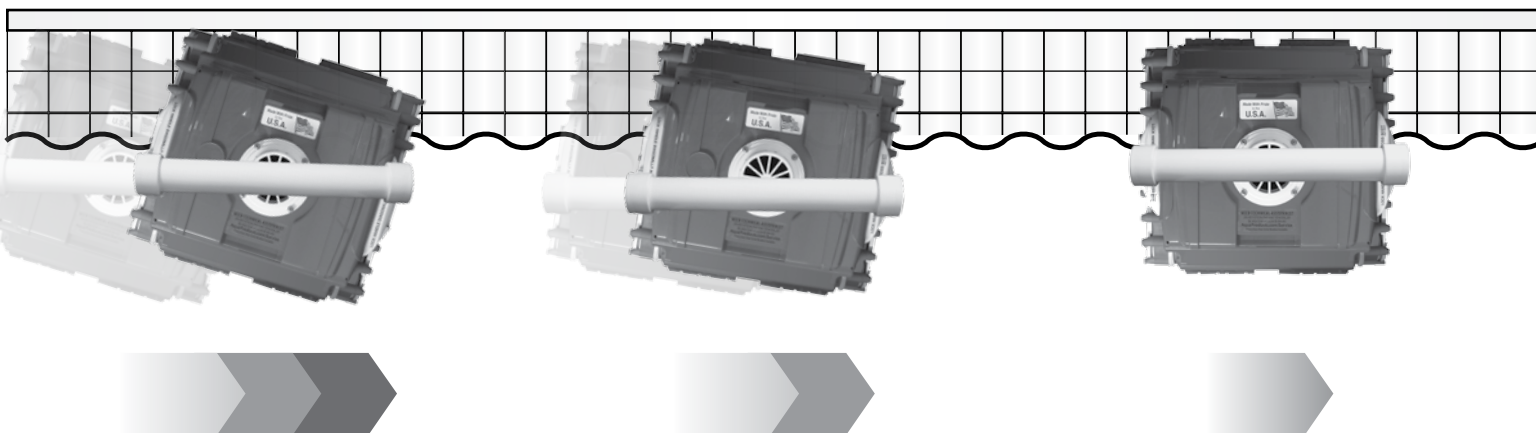

SETTING UP YOUR ROBOTIC POOL CLEANER

 **WARNING:** The Power Supply must be placed at least 12 feet / 4 meters from the pool's edge at all times!

 **WARNING:** A Ground Fault Circuit Interrupter (GFCI) / Residual Current Device (R.C.D.) must be installed to protect your electric outlet and to prevent any possible electrical shock!

2. SETTING UP THE POWER SUPPLY

Plug the Power Supply Cord into a standard Ground Fault Circuit Interrupted (GFCI) / Residual Current Device (R.C.D.) protected outlet. If your GFCI outlet is too far away and your cleaner does not have enough Cable to properly enter the pool at the midpoint of its longest side then you may use a proper outdoor grounded extension cord, but always keep the Power Supply at least 12' / 4 m from the pool's edge! (Fig 6a-b)

 **TIP!** To help protect your Cable from potentially getting pulled twisted, it is suggested to turn off your pool's filtration system while your cleaner is in operation to reduce the pool's filter circulation effect that may push and circulate the Cable.

NOTE: It is suggested to unplug your Power Supply when not in use to prevent accidental starts!

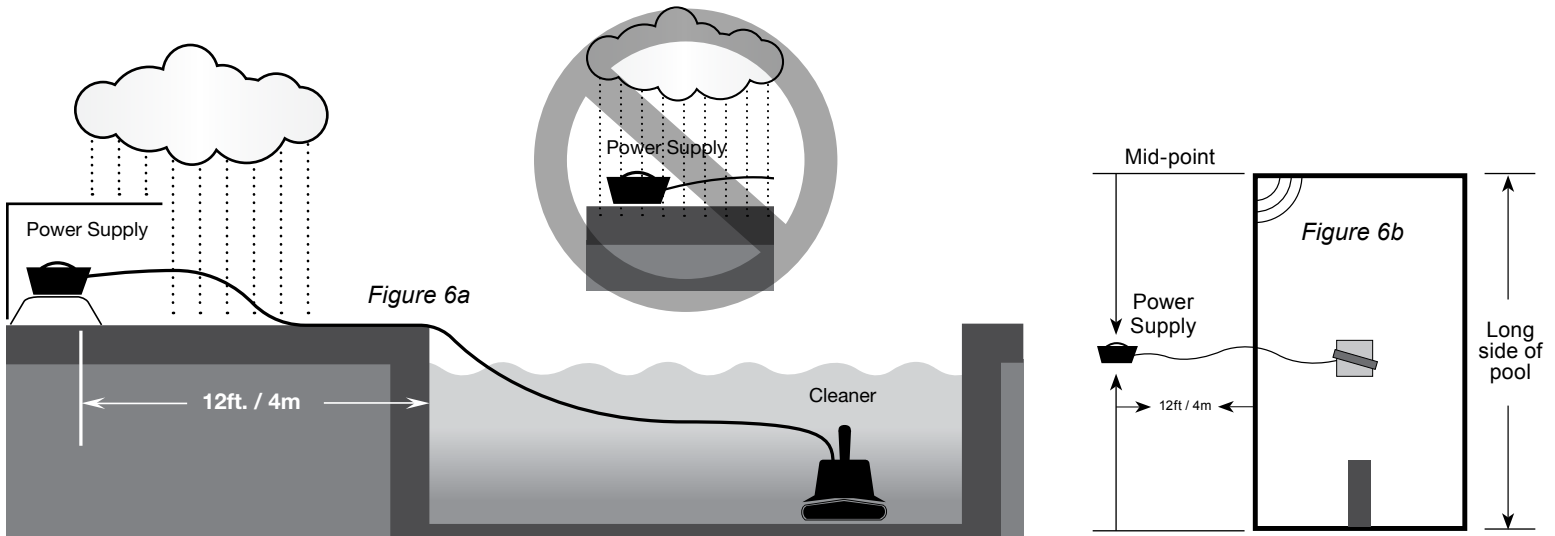

3. CLEANER START POSITION

A Place cleaner, upside down, in pool to release air bubbles.

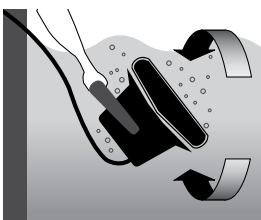

B Let cleaner sink level to the bottom of the pool (not on an incline)



C Turn Power Supply "ON"



KNOWING / USING MODEL FEATURES

SETTING THE POWER SUPPLY TIMER (INTERNAL AND / OR EXTERNAL)

Your cleaner has an adjustable Digital timer, which you can set for Continuous Run, Internal (Auto-shut off) Timed Power Supply or it may be connected to an external, separately purchased timer, such as a house-type timer or pool control system for External Timed Operation mode where you cleaner can externally be set to automatically turn ON / OFF / ON / OFF as needed.

CONTINUOUS RUN OPERATION (C-RUN)

Continuous Run mode means that the cleaner will operate continuously until the ON / OFF Switch to is physically pressed OFF or an external time source automatically turns OFF the power to the Power Supply. When manually pressing OFF, to restart its operation you must physically press the Switch back to ON. For automatic ON / OFF operation in "C-Run" mode, please refer to External Timed Operation instructions (Page 9).

Digital Timer (Fig. 7)

1. Turn the Main Power ON / OFF Switch to "ON".
2. Press the "C-Run" (Continuous Run) button until it is lit. Your cleaner is now set to Continuous Run mode.

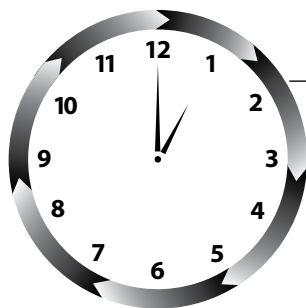
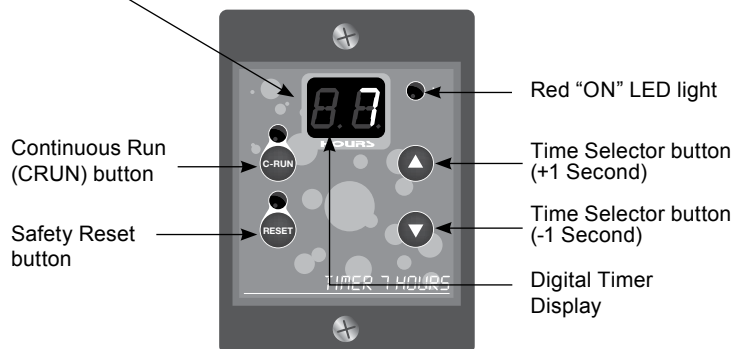

Figure 7
(Digital Timer)



IMPORTANT: In "Continuous Run" External Timed mode, the Safety Reset button feature becomes inactive and can not protect models with this feature from accidental "out of water" start up. Therefore, it is imperative that you always unplug the Floating Cable from its Power Supply when removing your cleaner from the pool!



WARNING: The mode for operating your cleaner should be set after the cleaner has been placed in the pool, the Floating Cable has been plugged into the Power Supply and the Power Supply has been plugged into the Ground Fault Circuit Interrupted (GFCI) / Residual Current Device (R.C.D.) protected electrical outlet with the Power Supply located at least 12 feet / 4 meters from the pool's edge!

INTERNAL TIMED OPERATION

Internal Timed Operation enables owners of Power Supply models equipped with either Dial or Digital timers to customize their cleaner's automatic operating cycle to clean anywhere from 1 to 7 hours and then automatically shut OFF. Once shut OFF the Internal Timed mode will not automatically turn the cleaner back ON.

1. Press the Main Power ON / OFF switch to the "ON" position.
2. Adjust the Timer Control to the desired cleaning time (1 to 7 hours) depending on suggested cleaning cycle for your model, pool size and amount of debris in pool (i.e. more debris = longer cleaning time).

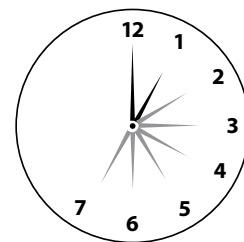

Digital Timers (Fig 7): Press the Time Selector Arrows Button upwards to increase time or downwards to decrease operating time. Each time you press up or down the digital face will display the number of hours of timed operation for.

NOTE: When pressing the Main Power Switch to "ON" should the Green LED above the C-RUN Button blink continuously then the Power Supply is currently set to the External Timed Operation mode and needs to be reset to the Internal Timed Operation mode by doing the following. Press and hold the C-RUN Button for approximately 5 seconds until the Green LED stops blinking and remains off. If it has stopped blinking and is off then the Internal Timed Operation mode is set.

3. Press the Safety Reset Button (Fig. 7). Your cleaner is now set to its Internal Timer and will begin cleaning for the amount of time set.

NOTE: Your Power Supply will remain in the Internal Timed Operation mode until you physically reset it to the External Timed Operation mode and will not reset to the External Timed Operation mode even if the power to the Power Supply is turned off or is set to the OFF position.

EXTERNAL TIMED OPERATION

Your Power Supply may be connected to an external separately purchased timer, such as a house-type timer or pool control system. In this External Timed Operation mode your cleaner can externally be set to automatically turn ON and OFF repeatedly per the external timer schedule set.

To connect your cleaner to your pool control system relay, please consult an electrician, your control system manufacturer or dealer for appropriate instructions.

Digital Timer (Fig. 7)

1. Connect your Power Supply to an external timer (that is plugged into a GFCI / R.C.D. protected outlet).
2. Press the Main Power Switch to "ON" and after a few seconds the Digital Timer Display will flash two horizontal lines. If the Green LED above the C-RUN Button blinks then the External Timed Operation mode is set.
3. If the Green LED above the C-RUN Button does not blink then it is still set to the adjustable Internal Timed Operation mode and needs to be reset to the External Timed Operation mode by doing the following.
4. Press the C-RUN Button once. The Green LED should illuminate.
5. Press and hold the C-RUN Button for approximately 5 seconds until the Green LED starts to blink. When it blinks then the External Timed Operation mode is set.

NOTE: Your Power Supply will remain in the External Timed Operation mode until you physically reset it to the Internal Timed Operation mode and will not reset to the Internal Timed Operation mode even if the power to the Power Supply is turned off or is set to the OFF position.



IMPORTANT: "Continuous Run" External Timed mode: The Safety Reset button feature becomes inactive and can not protect models with this feature from accidental "out of water" start up! Therefore, it is imperative that you always unplug the Floating Cable from its Power Supply when removing your cleaner from the pool!

DEBRIS INTAKE PORT WIDTH SELECTOR

Debris may vary due to geography, landscape or season. Therefore, your cleaner has been equipped with the ability to adjust the opening size of its Debris Intake Ports to accommodate larger or smaller debris.

For smaller dirt like pine needles, sand and pollen slide the Intake Port Width Selector (Figs. 9a-b), located on the inside of the Bottom Lid Assembly, in the direction of the arrow indicating "LESS". This will restrict the opening ability of the Port Flaps thus increasing its suction velocity to improve the removal of sediment dirt.

For larger debris like leaves, twigs and acorns slide the Intake Port Width Selector (Figs. 9a-b) away from LESS to increase the Port opening size to accommodate larger dirt and debris.

VARIABLE INTAKE PORT DEPTH EXTENSIONS

Similar to a house vacuum that offers varied heights to clean carpet and hard floors separately, your pool cleaner is equipped with the patented Variable Intake Port Depth Extensions. There are 2 pairs provided, each of different thickness / depths, offering varied depth suction points to access different types of dirt from different types of pool surfaces.

Use either the thicker pair to access heavy dirt like sand, algae or silt embedded in porous surfaces like gunite, plaster or pebbled textures or the thinner pair to access lighter dirt like pollen and dust in less porous surfaces like vinyl liners. You may even use one of each of the Port Depth Extension thicknesses to provide varied dirt accessibility or use none at all and allow the cleaner's standard suction depth of the Bottom Lid Assembly to do the job should your pool surface be virtually porous-free like fiberglass.

1. To install simply align each Variable Port Depth Extension tab to fit into its corresponding receptacle in the Bottom Lid Assembly. Be sure that the angled side of each "Extension" is facing the nearest Brushes (Fig. 10).

NEVERSTUCK™ ROLLERS

Two NeverStuck™ Rollers (Fig. 11) are located adjacent to the Vacuum Intake Ports (Figs. 9a-b) on the Bottom Lid Assembly. These help prevent the cleaner from being stuck on obstacles like raised drain covers, convex lights or in-floor pop-up heads. If they are not needed, the Rollers may be removed with a phillips head screwdriver.

POWER WASHING JET SYSTEM

Your model comes equipped with the Power Wash Hydroscrubbing Jet system (Fig. 12). An internal centrifugal pump produces two pressurized streams of water that help dislodge dirt like sand from seams, pores and corners where brushes can't reach. Periodically check the Power Washing Tubes (Fig. 12) to make sure that they are not clogged.

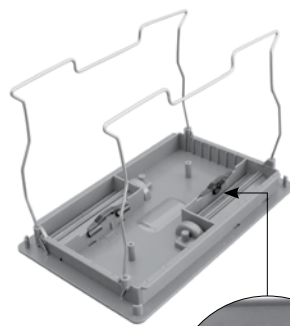

Figure 9a



Selector moved toward LESS

Figure 9b



Selector moved away from LESS

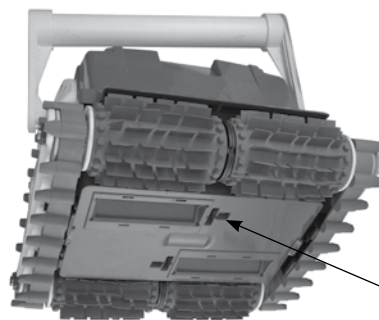

Figure 10

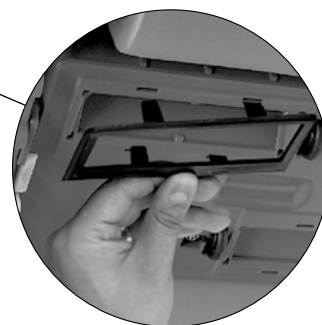

Figure 11

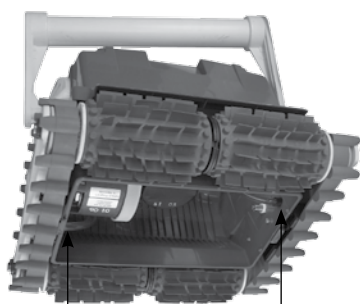
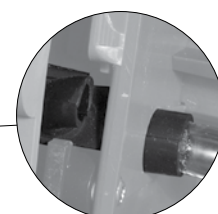
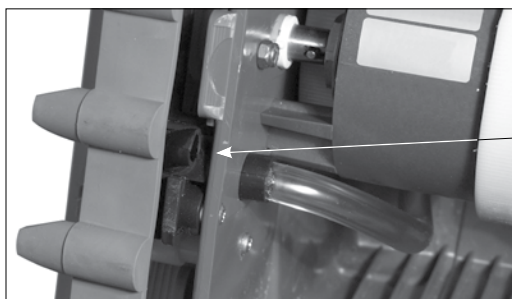

Figure 12



Close up of Power Wash exit port nozzle after removal of the Bottom Lid Assembly and Filter Screen.

CLEANING PATTERN / DIRECTIONAL GUIDANCE MECHANISM

CABLE FLOAT + 3 DIRECTIONAL REMOTE CONTROL

The Cable Float (Page 3; Fig. 2) is a flotation device that enables your cleaner to turn on the floor (rather than the wall), with limited lateral waterline movements, allowing your cleaner to spend more time on the floor, where the majority of debris resides. This offers faster, more efficient and complete coverage of virtually any pool configuration. Your cleaner will move down the wall and about halfway across the pool floor and then reverse. When it reverses its internal Pump Motor will temporarily turn off allowing the Cable Float to lift its side of the cleaner allowing only the opposing side to have traction. As the cleaner reverses, the side with traction will cause your cleaner to turn in an arc-radius manner. The internal Pump will turn back on and full traction will be regained, allowing the cleaner to continue in a straight line to the wall.

CLEANING PATTERN & CABLE FLOAT

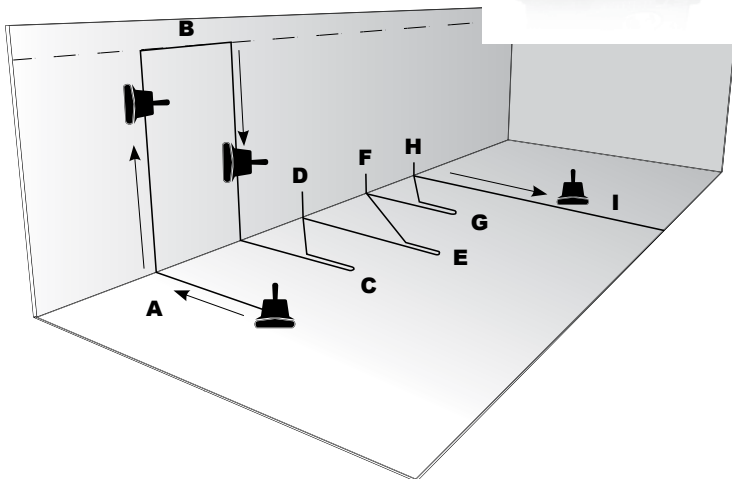

Pattern Description:

- * A. Your cleaner searches for the wall and climbs it.
- * B. Then spends a number of seconds moving across the waterline and then climbs down the wall.
- C. Your Cleaner moves across the floor to about half the width of the pool and then reverses backwards for a few seconds. The cleaner turns slightly and moves towards the wall again.
- D. Your cleaner climbs the wall for a couple of seconds.
- E. Your cleaner reverses to move back across the floor to about half the width of the pool and then reverses backwards for a few seconds. The cleaner turns slightly and moves towards the wall again.
- F. Your cleaner climbs the wall for a couple of seconds.
- G. Your cleaner moves across the floor to about half the width of the pool and then reverses backwards for a few seconds. The cleaner turns slightly and moves towards the wall again.
- H. Your cleaner climbs the wall for a couple of seconds.
- I. Your cleaner moves to the opposite wall to restart the full pattern.

NOTE: Your cleaner uses the Cable Float on the Floating Cable to lift itself on one side, which will allow your cleaner to pivot on the opposite side in order to turn.

* Internal program has a preset number of seconds for climbing.
In deep ends, it may not reach the waterline..

NOTE: Your cleaner is equipped with a safety feature that automatically reverses it after a number of minutes should it not locate a wall and tilt to approximately 90°. This protects your cleaner should it encounter the underside of a ladder for example and be unable to climb. Your cleaner also features a safety shut-off timer that periodically shuts off the power to your cleaner for a few seconds to allow it to float away from its position as an additional measure of protection against getting stuck.

MAINTAINING YOUR POOL CLEANER

CLEANING AND CHANGING THE FILTER BAG

Thoroughly cleaning the Filter Bag (Figs. 16a-b) after every use is the most important maintenance step you can take to ensure optimum performance of your cleaner. The Filter Bag's (Fig. 3) holding capacity is large in comparison to all other brands of independent pool cleaners, but far smaller than that of a pool's main filter. Perhaps it is more important to know that your cleaner's Filter Bag can filter out particles down to 20 times smaller than what many main filters can. This means that the fine particles such as algae and bacteria, invisible to the naked eye, which slip through the main filter and back into the pool to settle into the pores of the pool's surface, will be scrubbed loose and vacuumed up by your cleaner and retained in its Filter Bag. Therefore, although you may see only a fine coating of dirt, the Filter Bag itself may be deeply saturated with ultra fine particulate matter from your pool's large surface area and the flow of water through it becomes restricted and suction is reduced. This will result in remaining dirt and debris not being completely removed from the pool.

Also, strong water flow is required to force the cleaner against the wall when climbing. A dirty Filter Bag weighs the cleaner down, making it hard for your cleaner to climb due to the added weight and reduced water flow. This lack of climbing may limit your cleaner's ability to cover the entire pool and pick up any more dirt. Therefore, it is important to clean the Filter Bag thoroughly (Figs. 16a-b) with every use so that the fine particles that get trapped within the fibers of the Filter Bag are removed.

TO CLEAN THE FILTER BAG:

1. Unplug the Power Supply (Fig. 13).
2. If your cleaner is in the pool, gently pull it toward you using the Floating Cable (Fig. 14) until the Handle is within reach. Use the Handle (not the Floating Cable) to slowly pull your cleaner out of the pool after allowing most of the water to drain from your cleaner back into the pool.



IMPORTANT: Using the Floating Cable to lift the cleaner out of the water will cause severe damage to your cleaner and may result in costly repair!

3. Lay your cleaner on its back or side on a soft surface to avoid scratching it. Individually pull each Lock Tab gently away from your cleaner's body to free the Bottom Lid (Fig. 15).
4. Remove the Filter Bag from the Wire Frame Bag Supports (Fig. 9a), turn it inside out and with a high pressure garden hose, wash off all the dirt from the inside out or dunk it in a clean bucket of water and wring the Bag continuously until the rinse water is clear. If necessary, you may machine wash (Gentle Cycle / Cold Water only) the Bag with NO DETERGENT. You may re-install the bag immediately or allow it to air dry (never iron or machine dry the Filter Bag).
5. Re-install the Bag on the Wire Frames of the Bottom Lid Assembly, making sure that the "felt" (soft) side of the Fine Filter Bag is facing in. To ensure a proper fit of the Filter Bag onto the Bottom Lid Assembly, locate the Small Label near the Filter Bag's elastic bottom. Position the Filter Bag so that the Small Label is at the center of either long side of the Bottom Lid (Fig. 16b). Then pull the elastic bottom over each Wire (Figs. 16a-b) and slide the Filter Bag down along the Wires until the Bag reaches the Bottom Lid. At that point the Filter Bag's elastic bottom should be stretched over the plastic ridges located at the base of the Bottom Lid. This holds the Filter Bag in place. Pull the Filter Bag corners to the top corners of the Wire Frame and pull the extra Bag material from each corner inwards along the top center of the Wire Frames (Fig. 16b).
6. Re-install the Bottom Lid Assembly into the bottom of your cleaner. Be sure that the Filter Bag's fabric is not interfering with the locking of the Lock Tabs and that you clearly hear each Tab lock shut.

Figure 13

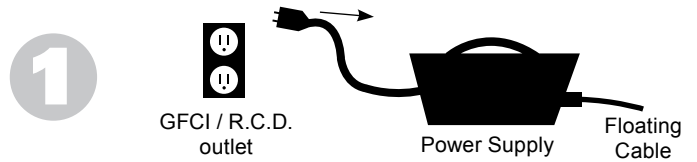

Figure 14

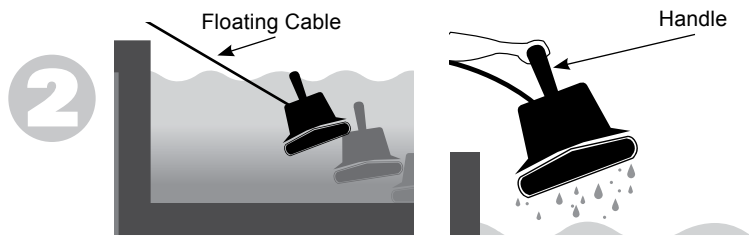

Figure 15

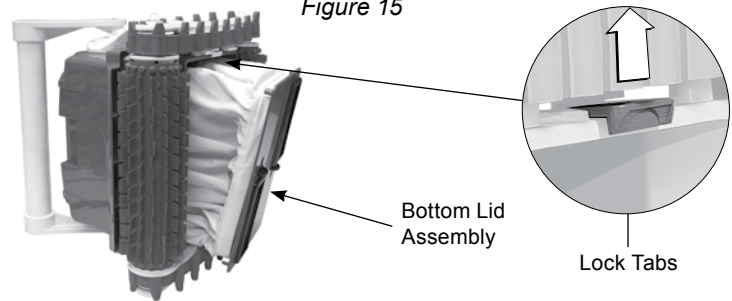

Figure 16a

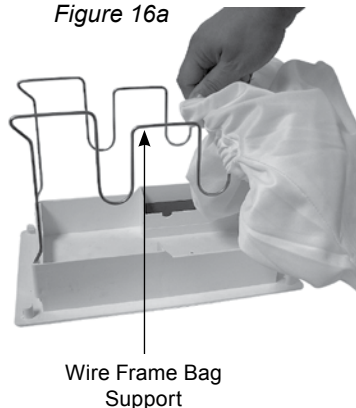
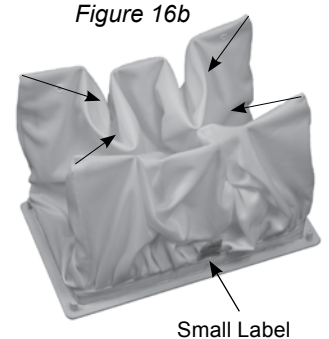

Figure 16b



IMPORTANT: Although a Filter Bag may appear clean it is capable of microfiltering out particulates 20 times smaller than what the naked eye can see! It is crucial to thoroughly clean the Bag with each use to ensure its ability to properly cover and clean your pool!

FLOTATION

Your cleaner is a universal pool cleaner which performs under varying chemical and temperature conditions in your pool. Your cleaner offers the best possible performance when it is virtually weightless in your pool. Therefore, careful balancing of its weight is important for proper operation. Generally, a new cleaner is universally balanced when used for the first time and additional Flotation (Fig. 17) is not required on start-up.

Figure 17

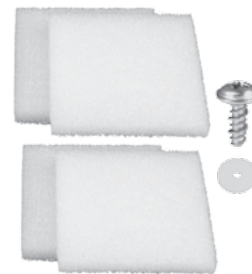

IMPORTANT: Careful removal of air trapped in the housing is critical. Each time you place your cleaner in the pool use the Handle (while submersed) to turn it upside down and gently rock it back and forth to allow any possible trapped air to escape! (See Page 7, Step 2)

Most pool conditions allow your cleaner to climb most stairs and pool walls effortlessly up to the waterline. *However, in some instances the pool environment (e.g. temperature, chemicals, water, etc.) may offset your cleaner's natural buoyancy. Therefore, flotation devices (Fig. 17) have been included in the packaging with your new cleaner to assist its buoyancy.

Adding Flotation on Bottom Lid Assembly (Fig. 18a-b):

1. Remove the Filter Bag (Fig. 18a). Then place the 2 Square Floats, foam side down, against the inside base of the Bottom Lid Assembly (Fig. 18b). Secure the Square Floats with the 2 Screws provided by fastening them in from the inside of the Bottom Lid Assembly. This should provide adequate buoyancy.
2. Should your cleaner require more Flotation, then repeat step 1 and add the 2 remaining Square Floats.

Figure 18a



Figure 18b

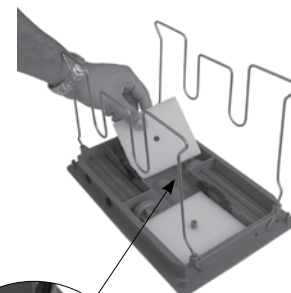

IMPORTANT: Temperature and chemical composition changes can greatly affect the buoyancy of your cleaner! Therefore, if you have previously installed Flotation devices in your cleaner to assist its buoyancy, it may be necessary to remove the devices one-by-one until proper buoyancy is restored!

PROPELLER CARE

It is a good practice to inspect the Propeller (Page 3; Fig. 1) once or twice per season to check for obstructions, which may reduce water flow and thus vacuuming ability and pool coverage.



IMPORTANT: To protect against personal injury and damage to your cleaner always unplug your cleaner from its Power Supply prior to performing any maintenance or repair procedures!

1. First unplug the cleaner from the Power Supply (Fig. 19a).
2. Then remove the Screws that secure the Outlet Top to the body (Fig. 19b-c). The Outlet Top has 4 Screws. Using a screwdriver or similar instrument, not your finger, turn the Propeller to check that it spins freely and inspect the Propeller for clogs: hair, twigs or other debris, which may keep it from spinning freely. Remove any accumulated material and replace the Outer Top.

1

Figure 19a

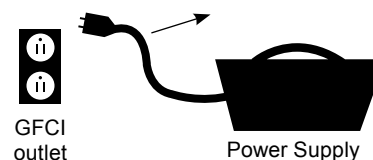

GFCI outlet

Power Supply

2

Figure 19b



Figure 19c



IMPORTANT: Be careful not to over-tighten the Screws or you may "strip" the screw holes or crack the Outlet Top when re-assembling!

FLOATING CABLE CARE

Occasionally you should stretch the Floating Cable (Page 3; Fig. 2) out to its full length to prevent a memory from forming and ensure your Cable will not impede your cleaner from reaching all areas of your pool. At that time you should also check the Floating Cable for external damage. Continual rubbing against sharp or rough surfaces may abrade the Floating Cable resulting in damage and possible short-circuiting your cleaner. Animal bites may puncture or fray the cable as well. For these reasons it is important to periodically inspect the Floating Cable. The following is not applicable to models with NO Handle, permanently fixed Handle or Handle with a Handle Float.

With every use, you must reverse the diagonal locked position. This will reverse the direction your cleaner travels in your pool ensuring that it reaches any areas possibly missed during its previous use and ensuring a tangle free Cable.



IMPORTANT: *Never lift your cleaner out of the pool using the Floating Cable! Your may use the Floating Cable to pull the cleaner to the side of the pool, but always use the Handle to remove it from the pool! Using the Floating Cable to remove the cleaner from the pool will result in internal connections being broken and costly damage being caused to your cleaner!*

SCRUBBING BRUSHES CARE AND REPLACEMENT

Your cleaner's Scrubbing Brushes provide traction and give it the ability to loosen debris. It is important that you not let the Brushes get worn down otherwise your cleaner may lose the ability to scrub, climb, turn and move to clean and cover all areas of the pool. Eventually you will need to change the Brushes on your cleaner. When they need replacement will depend upon how often you use your cleaner and upon the conditions of your pool. High chemical concentrations and rough surfaces will cause faster Brush wear. We recommend that you inspect Brushes frequently to check for excessive wear.

Figure 20

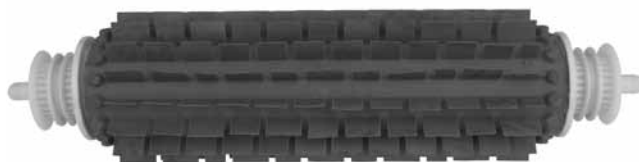

To protect against personal injury and damage to your cleaner always unplug your cleaner from its Power Supply prior to performing any maintenance or repair procedures!

CHANGING DRIVE TRACKS

Drive Tracks (Fig. 21) may become worn over the normal course of use and will require replacement based on the frequency of use, the pool's chemical balance, pool surface and length of season. Worn (stretched, loose or "flat-spotted") Drive Tracks may effect the cleaning pattern impeding its ability to cover the entire pool. If during your periodic inspection you find that your Drive Tracks are worn, please contact your Authorized Dealer for replacement Drive Tracks.

1. Unplug your cleaner from its Power Supply and remove your cleaner from the pool.
2. Place your cleaner on its side, on a soft surface which will not scratch the Body's finish.
3. With your thumbs pushing against the Side Plate (Fig. 22), hook your fingers under the Drive Track and pull it toward the Side Plate. When you get the Drive Track over the "lip" of the Side Plate, hold it there with one hand, and with the other hand, grip the Wheel Tube (Fig. 22) and rotate it away from the cleaner until the Drive Track "walks" over the Side Plate. Continue this until the Drive Track is free.
4. To mount the new Track, hook it around the lower Wheel Tube end and pull it upward as you guide it between the cleaner's Body and Side Plate.
5. Push inward on the Drive Track and force it over the edge of the Side Plate. Rotate the Wheel Tube, towards you, until the Drive Track properly seats itself on the Wheel Tube between the Side Plate and the cleaner's body
6. Repeat steps 1 through 5 with the Drive Track on the other side of the cleaner.

Figure 21



G-Tooth™
Drive Track

Figure 22



IMPORTANT: Always replace both Tracks at the same time! Replacing only one will adversely effect the cleaner's cleaning pattern!

CHANGING DRIVE BELTS

Drive Belts (Figs. 26a-b) may become worn over the normal course of use and will require replacement based on the frequency of use, the pool's chemical balance and length of season. Worn Drive Belts will impede your cleaner's ability to move or climb and may effect the cleaning pattern impeding its ability to cover the entire pool. If during your periodic inspection you find that your Drive Belts are stretched, loose or "flat-spotted" please contact your Authorized Dealer for replacement Drive Belts.

1. Remove Drive Tracks (See CHANGING DRIVE TRACKS).
2. Place the cleaner on a non-abrasive surface and turn cleaner upside down. Remove Bottom Lid Assembly (Fig. 23).
3. Remove the Wheel Tube Retaining Rings (Fig. 24).
4. Locate and remove 4 screws (see Fig. 25) on Drive Motor side, which holds Side Plate in place.

NOTE: Before removing the screws, notice how the Drive Belts, Drive Pulley, Stepped Sleeve Rollers, Small Rollers and Bushings are positioned for re-assembly (Figs. 26 a-b)



TIP! We suggest using needle nose pliers to remove the Wheel Tube Retaining Rings.

Figure 23

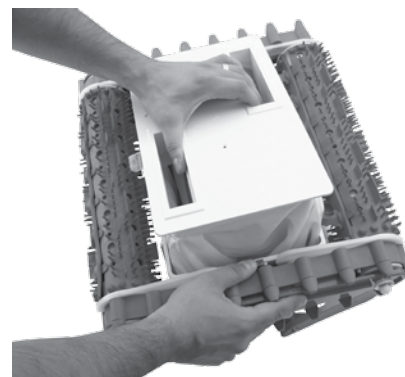

Figure 24



Wheel Tube Retaining Ring
"E" Clip

- Remove old Drive Belts and replace them with new Drive Belts, being careful to properly position the replacements: One Belt from the Drive Pulley to the Front Wheel Tube and one from the Drive Pulley to the Rear Wheel Tube. The Belts must press against the thicker side of the Stepped Sleeve Rollers for proper tension (Figs. 26 a-b).
- To re-assemble, reverse steps 5 through 2.



TIP! Please use the diagram below for Top View and Inside View of the Drive Belt Assembly (Figs. 26a-b).

Figure 25

4 Screws on Drive Motor side

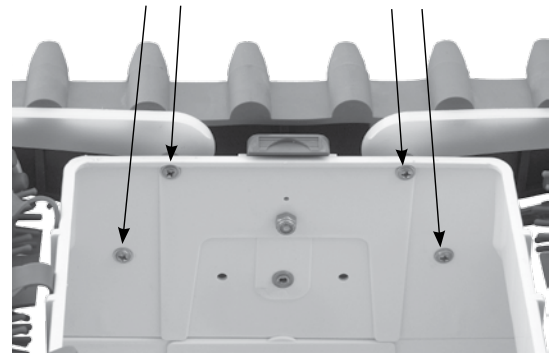

DRIVE BELT ASSEMBLY

Figure 26a
Inside View

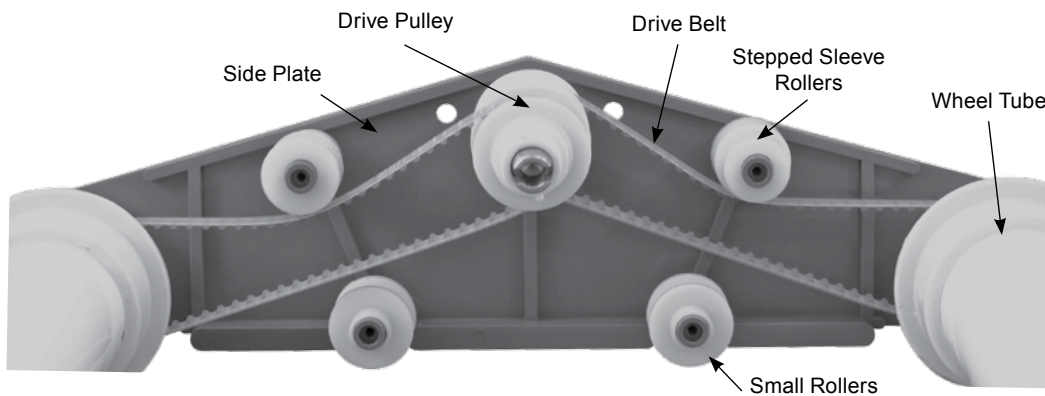
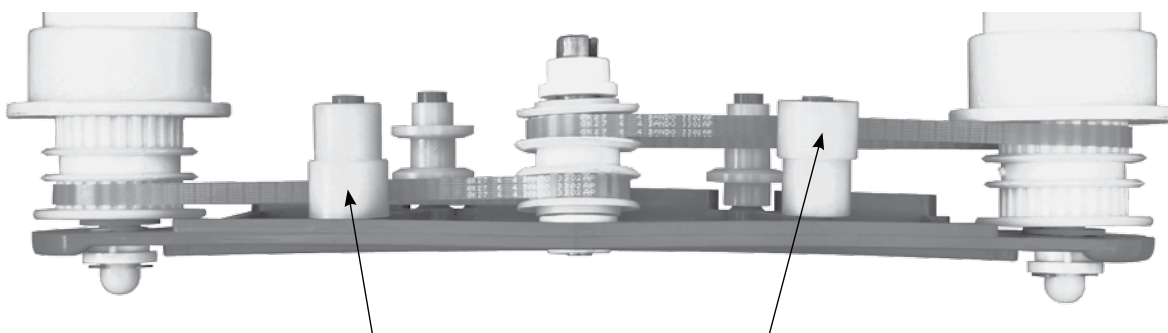

Figure 26b
Top View



NOTE: When re-assembling be sure that the Drive Tracks are positioned so that they press against the thick side of the Stepped Sleeve Rollers.

CLEANER STORAGE

When not in use it is important that your cleaner, its Floating Cable and Power Supply are properly stored in a clean and dry area, away from direct sunlight, protected from below freezing temperatures and exposure to chemicals and their fumes (i.e. chlorine). This will help prevent any unnecessary wear or damage to your cleaner or its components. Prior to storing your cleaner, thoroughly clean your Filter Bag and dry off your cleaner. Ensure that its Floating Cable is untangled, not twisted nor in a figure eight, but rather coiled either around your cleaner's body or in large circular loops and positioned under your cleaner. Be sure to rest your cleaner on its side so that its Brushes do not get flat spots.

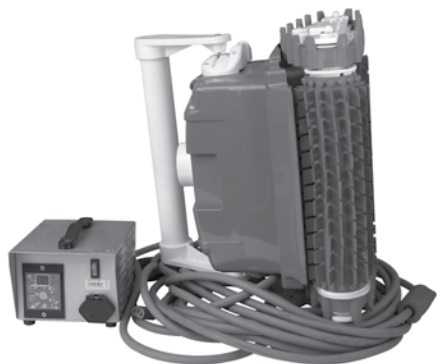

Correct

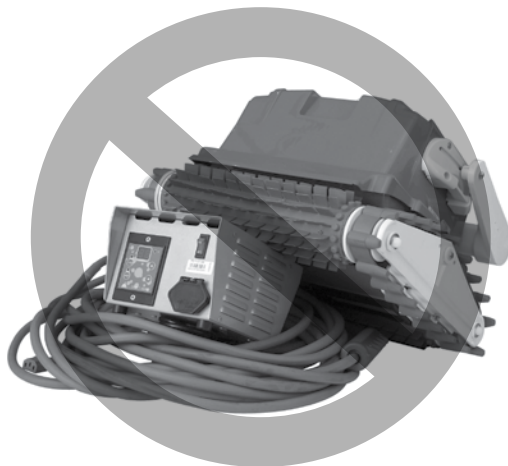

Incorrect
(do not place cleaner
on top of power supply)

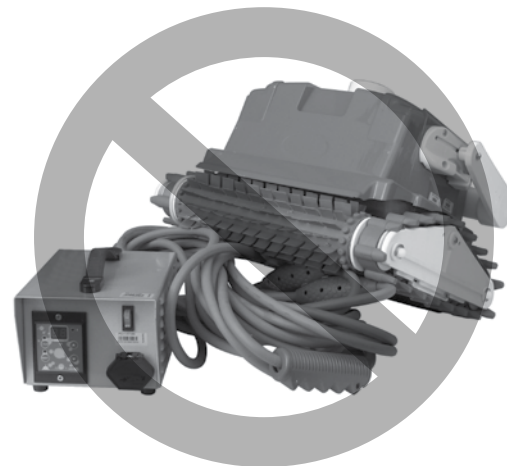

Incorrect
(do not coil cable in a
figure 8 configuration)

PREPARING YOUR CLEANER FOR SHIPPING

In the event that you should have to send your cleaner in for repair, you must package the cleaner properly to ensure it reaches the repair facility safely and without incurring damage during transport. This will delay your repair turnaround time and require you to contact your shipper directly to dispute damages.

NOTE: A log of all information from your contact with the Authorized Service Center (i.e. RMA, name, dates, cleaner model and serial number, etc.) should be kept with your operator manual and / or other important documents for your reference (See page 31: NOTES).

- 1 Ask the Service Center whether the Power Supply needs to accompany the cleaner. If yes, the Power Cord should be coiled (Fig. 27a) and the Power Supply should be entirely well wrapped in bubble-wrap or equivalent protective material (Fig. 27b). The Power Supply should be positioned in the center of the base of the shipping box and the shipping box base must be firmly sealed (Fig. 27b).

Figure 27a



Figure 27b



- 2** The cleaner's Floating Cable should be coiled and encircled around the Power Supply located at the base of the shipping box (Fig. 28).

Figure 28



- 3** A protective barrier (preferably thick cardboard) should be placed on top of the Floating Cable and Power Supply (Fig. 29).

Figure 29



- 4** Your cleaner should be completely wrapped in bubble-wrap or equivalent protective material. The protected cleaner should be positioned in the center at the base of the protective barrier that is shielding the cleaner from the Power Supply and the Floating Cable underneath. Insulated protective material like bubble-wrap should be placed between the cleaner and the shipping box at walls and top to secure the cleaner and around shipping during transit (Figs. 30-31).

Figure 30

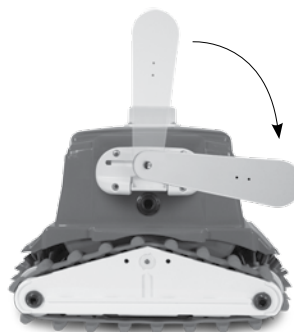

Figure 31



- 5** Include a copy of all information obtained during your contact with the Authorized Service Center, including your contact information and cleaner's serial number in an envelope (Fig. 32). A copy of the information relevant to the current technical issue should be sent in the packaging with your cleaner in an envelope. Please include a letter indicating the following:

- Technical issue
- Troubleshooting procedures that you completed
- Who you spoke with, when and what was determined
- Your contact information (name, email, phone number, address cleaner model name and serial number)

Figure 32



IMPORTANT: Keep a copy of your shipping information for tracking purposes! See page 25.

TROUBLESHOOTING GUIDE

~ SUMMARY ~

The most common troubleshooting issues are presented in this summary. Should you wish a more detailed description of a procedure or have other troubleshooting issues please refer to the In Depth Troubleshooting Guide on pages 20-24.



WARNING: Before performing any troubleshooting maintenance procedures on your cleaner, it should be disconnected from the Power Supply (transformer) and the Power Supply should be unplugged from the electrical outlet to prevent the possibility of personal injury or damage to the cleaner!

1. PUMPS WATER, BUT DOES NOT MOVE OR MOVES SLOWLY

- A. Remove any foreign matter that may be obstructing Drive Track (Page 15; Fig. 22) movement.
- B. Check Drive Belts and Drive Tracks (Pages 15-16). Make sure they have not slipped out of place and that they are not loose.
- C. With cleaner upside down on a soft surface (to protect from scratching its body) plug Power Supply in and turn it on for less than a minute to observe whether the Drive Pulley (Page 16; Figs. 26a-b) is turning. If it is not moving please contact an Authorized Service Center.

2. MOVES BUT DOES NOT PICK UP DIRT AND DEBRIS (DOES NOT PUMP WATER)

- A. Clean the Filter Bag thoroughly (Page 12).
- B. Ensure that the Debris Intake Port Flaps on the underside of the Bottom Lid Assembly (Page 4; Fig. 3) are free to open and close.
- C. Adjust Intake Port Width Selector Switch towards "LESS" (Page 10; Figs. 9a-b).
- D. Make sure Pump Motor (Page 3; Fig. 1) is working properly and that the Propeller is not being slowed or stopped due to debris caught around it (Page 13, PROPELLER CARE).
- E. Remove Outlet Top by removing screws located at the top and clean any hair or debris on or around the propeller (Page 13, PROPELLER CARE). When reassembling the Outlet Top, BE CAREFUL NOT TO OVER-TIGHTEN THE SCREWS.

3. FLOATING CABLE (PAGE 3; FIG. 2) GETS WRAPPED AROUND THE CLEANER OR PULLED INTO THE CLEANER

- A. Make sure Floating Handle (Page 6) is locked at an angle across the cleaner's body. Reverse the diagonal direction of the Floating Handle with each use.
- B. If your pool's main filter is on while you are using your cleaner, turn off the filter.
- C. Remove any trapped air and additional Flotation that you may have added (Page 13, FLOTATION).
- D. Power Supply must be at least 12 feet / 4 meters from the pool's edge and positioned at the mid-point of the pool's longest side allowing only enough Floating Cable in the pool. This allows your cleaner to reach all areas (Page 7; Figs. 6a-b).
- E. Please contact an Authorized Service Center. To locate a Service Center, please visit AquaProducts.com/SCL

4. FALLS OR FLIPS BACKWARD OFF OF THE WALL

- A. Make sure Pump Motor (Page 3; Fig. 1) is working properly and that the Propeller is not being slowed or stopped due to debris caught around it (Page 13, PROPELLER CARE).
- B. Check Scrubbing Brushes for wear (Page 14, SCRUBBING BRUSHES CARE AND REPLACEMENT).
- C. Remove Flotation (Page 13, FLOTATION).
- D. Floating Handle (Page 6) should be locked diagonally and be sure that no water is present within. If water is present, please contact an Authorized Service Center. To locate a Service Center, please visit AquaProducts.com/SCL

5. DEBRIS COMES OUT OF THE CLEANER WHEN REMOVING IT FROM THE POOL - BOTTOM LID ASSEMBLY, DOES NOT CLOSE PROPERLY

- A. Make sure Filter Bag is mounted properly onto the Bottom Lid Assembly (Page 12; Figs. 16a-b).
- B. Make sure Debris Intake Port Flaps on underside of your cleaner move freely to open and close (Page 4; Fig. 3).
- C. Make sure Pump Motor (Page 3; Fig. 1) is working properly and that the Propeller is not being slowed or stopped due to debris caught around it. (Page 13, PROPELLER CARE)

6. DOES NOT PUMP WATER OR MOVE, OR POWER SUPPLY (PAGE 4; FIG. 4) DOES NOT TURN ON

- A. Check to see if electrical outlet has power.
- B. Check the Fuse in the Power Supply (Page 4; Fig 4). If necessary, replace with the same type / amperage Fuse. If unsure as to Fuse type, please contact an Authorized Service Center. To locate a Service Center, please visit AquaProducts.com/SCL



WARNING: Before performing any troubleshooting maintenance procedures on your cleaner, it should be disconnected from the Power Supply (transformer) and the Power Supply should be unplugged from the electrical outlet to prevent the possibility of personal injury or damage to the cleaner!

- C. Make sure Cable Plug (Page 5; Fig. 5b) fits tightly into Power Supply.
- D. Make sure that the Power Switch is "ON". Then press the Safety Reset Button (Page 8; Fig. 7).
- E. First, unplug the Power Supply from the outlet! Then, using a cotton swab, dry any moisture within Fuse Holder (Page 4; Fig. 4) and on fuse itself.
- F. Check Floating Cable (Page 3; Fig. 2) and Power Supply Cable for possible cuts or damage.

7. DOES NOT CLEAN ENTIRE POOL (MISSES AREAS) OR DOES NOT CLIMB WALLS

- A. Make sure cleaner climbs walls up to the waterline and moves left or right before reversing (Pages 11, CLEANING PATTERN).
- B. Floating Handle should be locked at an angle across the unit's body (Page 6), and be sure that no water is present in the Floating Handle. If water is present, please visit contact an Authorized Service Center.
- C. Clean Filter Bag thoroughly (Page 12).
- D. Install Flotation to help the cleaner climb partially if it's not climbing (Page 13, FLOTATION).
- E. Operate the cleaner several cycles (up to 7 hours each), each time locking the Floating Handle in opposite directions and starting the cleaner in different areas of the pool.

8. GETS STUCK ON LADDERS, MAIN DRAINS, RETURN FITTINGS, LIGHTS, STAIRS OR IN CORNERS

- A. Remove obstructions from pool walls and floor if possible.
- B. Check Scrubbing Brushes for wear (Page 14, SCRUBBING BRUSHES).
- C. Adjust Flotation (Page 13, FLOTATION).
- D. Inspect / Clean NeverStuck™ Rollers (Page 10; Fig. 11) so that they spin freely.

9. POWER SUPPLY APPEARS TO SHUT OFF BEFORE COMPLETING A CLEANING CYCLE

- A. Unplug the Power Supply and check the Fuse (Page 4; Fig. 4).
- B. Make sure that the Timer is set correctly (Page 8).

10. DOES NOT SINK OR FLOATS AWAY FROM THE WALL

- A. Check that the Floating Handle is locked and in the correct position.
- B. Remove any additional Flotation and trapped air (Page 7, CLEANER START POSITION).

11. MAKES LOUD NOISES

- A. Allow your Filter Bag to continue to trap debris and particles until your cleaner no longer climbs as high at the waterline and its top Debris Intake Ports (Page 3; Fig. 3) begin to submerge and the noise lessens.
- B. Remove any added Flotation (Page 13) one-by-one until proper buoyancy has been restored.
- C. Apply non-water soluble grease or oil to components.
- D. Check Drive Belts and Drive Tracks (Page 15-16) for proper alignment and tension.
- E. Check for squeaking or grinding.

12. CLIMBS TO THE WATERLINE THEN MOVES LEFT WHEN FLOATING HANDLE IS LOCKED IN ONE DIRECTION, BUT DOES NOT MOVE RIGHT WHEN HANDLE DIRECTION IS REVERSED

- A. Check that the Floating Handle (Page 5-6) is locked and in the correct position.
- B. Insert one Square Float into the Bottom Lid Assembly (Page 13; Fig. 18a-b).

TROUBLESHOOTING GUIDE

~ IN DEPTH ~



IMPORTANT: Before performing any troubleshooting maintenance procedures on your cleaner, it should be disconnected from the Power Supply (transformer) and the Power Supply should be unplugged from the electrical outlet to prevent the possibility of personal injury or damage to the cleaner.

PUMPS WATER, BUT CLEANER DOES NOT MOVE OR MOVES SLOWLY

Remove the cleaner from the pool and place it upside down (on a non-abrasive surface so that it won't become scratched or scuffed) and unplug it from the Power Supply.

1. Check for and remove any debris such as hair, string, or leaves that may be obstructing the free movement of the Drive Pulley (Page 16; Figs. 26a-b), Drive Belts or Drive Tracks (Page 15-16).
2. Check that the Drive Belts and Drive Tracks are properly aligned and are taut (Page 16; Figs. 26a-b). Adjust or replace if necessary .

Then, plug the cleaner into the Power Supply , grab the Handle, lift your cleaner off the ground and turn it on outside the water while still upside down. Allow the cleaner to run a maximum of 1 minute to check the following:

3. Check that the Drive Pulley (Page 16; Figs. 23a-b) is turning. If it is not, grip one Wheel Tube with both hands and rotate it forward and reverse to see if the Drive Motor (Page 3; Fig. 1), to which the Drive Pulley is connected, loosens and begins to operate correctly.

If you have checked all of the options offered and the problem has not been corrected then please contact an Authorized Service Center. To locate a Service Center, please visit AquaProducts.com/SCL

MOVES BUT DOES NOT PICK UP DIRT AND DEBRIS (DOES NOT PUMP WATER)

1. Turn off the Power Supply, remove the cleaner from the pool, and unplug it from the Power Supply.
2. Clean the Filter Bag thoroughly (Page 12; Figs. 16a-b) so that the fine particles of dirt that get trapped within the fibers of the Filter Bag are removed. Keep in mind that the Filter Bag is capable of trapping particulates 20 times smaller than what the naked eye is capable of seeing. To ensure that the Filter Bag is not the issue and is cleaned, remove the Bag from your cleaner and operate it. If it now operates properly, then the Filter Bag requires a more thorough cleaning to remove the particulates from the fibers of the Bag.
3. Check the Intake Valve Flaps (Page 10; Figs. 9a-b) on the underside of your cleaner. The Flaps should move freely to open and close. Clean and free the Valve Flaps if necessary.
4. Adjust Intake Port Width Selector Switch (Page 10; Figs. 9a-b) towards "LESS".
5. Inspect / Clean Power Washing Jet Tubes (Page 10; Fig. 12).
6. Using a screwdriver, remove the screws that secure the Outlet Top to the body and inspect the Propeller for clogs, hair or other debris which may keep it from spinning freely (Page 13, PROPELLER CARE). If the Pump is operating properly replace the Outlet Top (Page 13, PROPELLER CARE). Be careful not to over tighten and "strip" the screws. If it appears to be frozen and no debris is blocking it movement, or if the Propeller moves freely when spun manually but not when the cleaner is turned on, or if the propeller is loose and wobbles when spun manually, please contact an Authorized Service Center. To locate a Service Center, please visit AquaProducts.com/SCL
7. Check the operation of the Pump Motor (Page 3; Fig. 1). While your cleaner is on in the pool, hold your cleaner by its Floating Handle (Page 3; Fig. 1) so that its Outlet Top (Page 3; Fig. 1) protrudes just slightly out of the water. Look to see that water is gushing from the Outlet Top.

FLOATING CABLE GETS WRAPPED AROUND BRUSHES OR PULLED INTO THE CLEANER

Check that the Floating Handle is locked diagonally across top of body and diagonal angle is reversed with each use (Page 5-6 FLOATING HANDLE).

FLOTATION (PAGE 13, FLOTATION)

Check the amount of Flotation that has been added to your cleaner. By removing Floats one at a time and checking its operation, you may be able to reduce the buoyancy to the appropriate level to avoid having your cleaner climb too high as to allow the Floating Cable to get pulled into the Brushes / Wheel Tubes.



IMPORTANT: Your cleaner is equipped with a special safety device that allows the cleaner to sense the Floating Cable being pulled into the Wheel Tubes and will try to immediately reverse its movement to push the Cable back out! If unsuccessful the cleaner will automatically turn off to protect it from twisting the Cable! Simply turn your Power Supply OFF correct the Cable and turn your Power Supply ON as normal to continue cleaning.

AIR

Careful removal of air trapped in the housing is critical to ensure natural balancing of your cleaner. Each time you place your cleaner in the pool use the Floating Handle (while submerged) to turn your cleaner upside down turning it side to side to allow any possible trapped air to escape!

FLOATING CABLE (PAGE 7, SETTING UP THE POWER SUPPLY)

Ensure that the Floating Cable is untangled and spread out on top of the water, allowing enough length for your cleaner to reach all areas of the pool without restriction and without excess of Floating Cable. Excess cable should be kept coiled outside the pool near the Power Supply. For best results, place the Power Supply at the mid-point of the pool's longest side (Page 7; Fig. 6a-b).

Should the Floating Cable continue to get tangled in or around the cleaner, contact an Authorized Service Center. To locate a Service Center, please visit AquaProducts.com/SCL

FALLS OR FLIPS BACKWARDS OFF WALLS OR STAIRS

CLEAN FILTER BAG (PAGE 12, CLEANING AND CHANGING THE FILTER BAG)

REMOVE FLOTATION (PAGE 13, FLOTATION): Remove Flotation one by one until proper buoyancy is returned. Be sure to always submerge your cleaner and holding its Floating Handle turn upside down to remove any air that may be trapped within the cleaner's body. Careful removal of air trapped in the housing is critical to ensure natural balancing of your cleaner (Page 7, CLEANER START POSITION).

FLOATING HANDLE (PAGES 5-6, FLOATING HANDLE): Check the handle position according to your model. Also check that there is no water present inside the handle.

CHECK THE OPERATION OF THE PUMP MOTOR

Make sure Pump Motor (Page 3; Fig. 1) is working properly and that the Propeller is not being slowed or stopped due to debris caught around it (Page 13, PROPELLER CARE).

If this situation persists, please visit your local Authorized Service Center. To locate a Service Center, please visit AquaProducts.com/SCL

DEBRIS COMES OUT OF THE CLEANER WHEN REMOVING IT FROM POOL (BOTTOM LID DOES NOT CLOSE PROPERLY)

FILTER BAG

Ensure that the Filter Bag is properly mounted on the Wire Bag Support Frame (Page 12; Figs. 16a-b). The Filter Bag's small Label on the elastic edge should be on the outside of the bag and positioned at the center of either long side of the Bottom Lid Assembly plastic. Stretch the elastic bottom over each Wire and slide the Filter Bag down until the Filter Bag reaches the Bottom Lid plastic. At that point the Filter Bag's elastic bottom should be stretched over the plastic lips located on each short side of the Bottom Lid Assembly, and will hold the Filter Bag in place. Pull the Filter Bag top corners into each of the top 4 corners of the Wire Frame. Insert the Bottom Lid into the bottom of the cleaner. Be sure that the Filter Bag's fabric is not interfering with the locking of the Lock Tabs. Be sure that each of the Lock Tabs are "Locked" closed (Page 12, CLEANING AND CHANGING THE FILTER BAG).

DEBRIS INTAKE PORT FLAPS (PAGE 4; FIG. 3)

Check that the Intake Valve Flaps on the underside of your cleaner (in the Bottom Lid Assembly) move freely to open and close (Page 4; Fig. 3). Clean Flaps if necessary.

LOCK TABS (PAGE 12; FIG. 15)

Check that the Lock Tabs are not warped. They should be straight and aligned with the cleaner's body. If they are warped then replacement Lock Tabs are available for purchase through your Authorized Service Center. To locate a Service Center, please visit AquaProducts.com/SCL

DOES NOT PUMP WATER OR MOVE, OR POWER SUPPLY DOES NOT TURN ON

It is unlikely that both Motors (Drive Motor and Pump Motor) are experiencing mechanical problems. In most cases the issue lies with something that is hindering the flow of electricity from the electrical outlet to the Power Supply (Page 4; Fig. 4) or through the Floating Cable (Page 3; Fig. 2) to the cleaner itself. To locate and resolve where electrical flow is being hindered check the following:

ELECTRICAL OUTLET & CONNECTIONS

Make sure that the Power Supply is firmly plugged into a grounded electrical outlet which has power. To test the outlet, plug in another electrical instrument that you know works to the outlet.

Check that the Floating Cable is securely plugged into the Power Supply.

POWER SUPPLY AND FUSE (PAGE 4; FIG. 4)

1. Check that the Power Switch is pressed upwards to the “ON” position.

NOTE: Your cleaner's Power Supply has a Safety Reset Button, which must be pressed each time you switch the power “ON”. The Safety Reset button does not need to be pressed each time if your Power Supply is operating off of an External Timer.

2. Switch the Power Supply “OFF” and “ON” several times, allowing approximately 30 seconds between each “ON” and “OFF”. Remember, if your cleaner is set to operate off an External its Reset Switch must be pressed each time after pressing the “ON” button.
3. Unplug the Power Supply from the electrical outlet. Check that the Fuse (Page 4; Fig. 4) in the Power Supply's Fuse Holder appears operational. If the Fuse appears burned out, then replacement Fuses are available for purchase through most major electronic supply stores, including your Authorized Dealer.
4. After unplugging the Power Supply from the electrical outlet, use a cotton swab to dry all sides of the Fuse and Fuse Holder (inside and out). Reinsert Fuse and plug in and start Power Supply.

CABLE ASSEMBLY (PAGE 3; FIG. 2)

With the Power Supply unplugged, check the Power Supply Cable (Page 4; Fig. 4) and the Floating Cable (Page 3; Fig. 2) for cuts or damage. If you detect damage to either Cable, contact an Authorized Service Center. To locate a Service Center, please visit AquaProducts.com/SCL

DOES NOT CLEAN ENTIRE POOL (MISSES AREAS) OR DOES NOT CLIMB WALLS

Your cleaner is designed to clean the pool many times over within its recommended cleaning cycle (up to 7 hours) by moving along the width of the pool (side wall towards side wall), not the length.

Your cleaner operates by moving down 1 side wall, then crossing over 50% of the floor's width, stop and reverse on an angle or arc to move back towards the original side wall. Once the cleaner reaches the original wall it will reverse and repeat this process with varied distances across the width of the pool. It will only climb the original wall every 4 times. Your model does not require constant lateral waterline movement to navigate the pool due to their patented turning systems. 3 Directional Remote Control models may be guided forward, reverse and in an arc radius turn (in the direction it is moving) using the handheld wireless Remote Control at any time to clean areas that may have been missed, need extra attention or for quick spot cleaning (Page 11, CLEANING PATTERNS).

If large portions of the pool are missed, then please check the following:

1. Be sure that the Power Supply and is located in the center of either one of the long sides of the pool. This will allow optimum use of the Floating Cable's length (Page 7, SETTING UP THE POWER SUPPLY). Make sure the Floating Cable is untangled and spread out on the water's surface and that there is adequate Cable length for cleaner to reach all areas of the pool.
2. The Fine Filter Bag may remove particulates 20 times smaller than what is visible to the naked eye. Thoroughly clean the Filter Bag to remove it of the fine particles embedded within the Bag fibers (Page 12, CLEANING AND CHANGING THE FILTER BAG). *To test if the Filter Bag is inhibiting the cleaner's performance, simply remove the Filter Bag from the Bottom Lid Assembly (Page 12).* Then re-insert the Bottom Lid Assembly into the cleaner and operate the cleaner without the Bag. If the cleaner pumps water strongly, and climbs the walls properly, then you have confirmed that the Filter Bag requires a thorough cleaning.

NOTE: When at the waterline a portion of the Brushes should be out of the water and your cleaner should move left or right along the waterline. Should it not reach the waterline then it will be slightly limited in its movement around the pool..

3. Shake the Floating Handle (Page 3; Fig. 1). Listen for the presence of water within it. The Handle should be lightweight and airtight without water in it. If water is present, contact an Authorized Service Center. To locate a Service Center, please visit AquaProducts.com/SCL
4. Check that the Pump Motor (Page 3; Fig. 1) is operating. Please refer to Page 21 titled MOVES BUT DOES NOT PICK UP DIRT AND DEBRIS.
5. Remove obstructions from your pool. Objects protruding from walls may impede the left/right movement of your cleaner when it is at the waterline causing the cleaner to remain in one or two sections while missing others. For optimal performance, it is recommended to remove objects from the pool walls when operating your cleaner. If some objects, such as ladders, can not be removed during your cleaner's cleaning cycle, place the cleaner in each of the 'separate' portions of the pool allowing each portion separate complete cleaning cycles. In this case position the Power Supply at the opposite ends of the pool during each cleaning cycle, while always keeping the Power Supply at least 12 feet / 4 meters from the pool's edge.
6. Check that the Drive Belts and Drive Tracks are properly aligned and are taut (Pages 15-16). Adjust or replace if necessary.
7. Check for excessive wear of the Scrubbing Brushes, which provide traction for climbing and replace if necessary (Page 14, SCRUBBING BRUSHES CARE AND REPLACEMENT).

8. You may need to add Flotation. Your cleaner needs to properly climb the walls and to move left or right scrubbing the waterline in order to properly clean the entire pool (Page 13, FLOTATION).
9. With your hand feel the lower surface of your pool walls just above the floor. In rare instances the pool walls may be slippery due to either algae or a newly polished finish and will require manual cleaning/brushing first.

Please see a water chemistry specialist, such as your Authorized Dealer, for proper treatment of your algae type. If it is suggested to "Shock" your pool, and then manually brush and vacuum the dead algae from all surfaces to remove the bulk of the algae from the pool, please know that if you use your cleaner to remove the dead algae then the Filter Bag will clog quickly, requiring several cleaning cycles and many through Filter Bag cleanings. Additionally, your cleaner's Brushes will become covered with algae and will require that they be thoroughly cleaned to ensure traction for further use.



IMPORTANT: When shocking your pool water, remove your cleaner from the water for at least 24 hours to allow proper dilution before returning the cleaner to the pool! Otherwise the heavy concentrations of chlorine may burn away your cleaner's motor seals, resulting in motor replacement, including having premature discoloration and wear of plastic and other rubber components!

10. If you use a non-chlorine coagulating solution (i.e. Baquacil®) to clean your pool a clear slick film may form along your pool's walls impeding the cleaner's ability to climb. We suggest adding 225 to 300 parts per million of Calcium Hardener to your pool water to combat the film build-up.

GETS STUCK ON LADDERS, MAIN DRAINS, RETURN FITTINGS, LIGHTS, STAIRS OR IN CORNERS

Cleaners have approximately one inch of clearance between the floor and its underside. The Brushes (Page 14, SCRUBBING BRUSHES CARE AND REPLACEMENT) enable the cleaner to climb over most obstacles like main drains, return filters, lights, and pop-up, in-floor systems, and to climb up stairs in most pools. But, in some cases, the size or convex surface of some of these obstacles (i.e. lights, raised main drains) are too great and stop the cleaner from moving forward or reverse by catching on the underside of the cleaner.

Follow these recommendations to assist your cleaner with the following obstacles:

LADDERS, RETURN FITTINGS, LANE HOOKS, LIGHTING FIXTURES

Objects protruding from walls may impede the left / right (lateral) movement of your cleaner when it is at the waterline. For optimal performance, it is recommended to remove objects from the pool walls when operating your cleaner. The greater the number of objects on the pool walls, the greater the difficulty your cleaner will have covering the entire pool. Two or more objects in the pool positioned either directly opposite one another, or diagonally across from one another, will restrict your cleaner to primarily clean only one section of the pool on one side of the objects during its cleaning cycle.

If these objects can not be removed then place the cleaner in each of the 'separate' areas of the pool, allowing each a separate complete cleaning cycle, starting your cleaner at the farthest points of the pool at the beginning of each cleaning cycle. If necessary, you may reposition your Power Supply to the mid-point of either short side of your pool's width, always keeping the Power Supply at least 12 feet / 4 meters from the pool's edge, to allow adequate Floating Cable length to reach all areas of the pool.

MAIN DRAINS

Contact an Authorized Dealer location to purchase a main drain guard, which will prevent your cleaner from becoming stuck on the Main Drain.

RETURN FITTINGS

Contact your Authorized Dealer for return fittings of the same diameter as your current fittings, yet with smaller extensions (under 1" / 2.5cm height). This should provide the clearance needed for your cleaner to climb freely.

NOTE: The bottom step of a ladder may stop your cleaner from freely climbing and tilting 90° up the wall from the floor. This means the cleaner will remain in the forward mode, 'spinning its wheels', under the ladder, not allowing its internal incline sensors to detect the wall. Fortunately, your cleaner is equipped with safety timer that will automatically reverse your cleaner after a period of time. This means the cleaner may not reach the waterline in that specific area and may slightly affect its cleaning pattern.

SCRUBBING BRUSHES (PAGE 14)

Check that your Brushes are plush and not worn. Should they require replacement, replacement sets are available for purchase through your Authorized Dealer. (For replacement instructions see page 14).

INCLINE SENSORS

Always start your cleaner on a horizontal level surface with both Brushes touching the floor. Should your cleaner begin its cleaning cycle in an incline, the Incline Sensors within the Drive Motor may begin operating assuming that the incline angle is a level floor. When the cleaner does become level, the Incline Sensors will tilt and consider the floor to be the wall. This will offset its operation, resulting in insufficient cleaning due to remaining in forward or reverse positions for great lengths of time when not needed.

POWER SUPPLY APPEARS TO SHUT OFF BEFORE COMPLETING A CLEANING CYCLE

1. Unplug the Power Supply and check the Fuse (Page 4; Fig. 4) to see if it is blown. If the Fuse appears burned out, then replace it with the same type / amperage Fuse.
2. If your cleaner's Power Supply is connected to an external timer, check to make sure that the external timer source is set for the desired cleaning cycle timeframe. If it has, then please contact your local electronics supply store to purchase a 5 Amp Slo Blow Fuse to replace the existing blown fuse.

DOES NOT SINK OR FLOATS AWAY FROM THE WALL

Clean the Filter Bag thoroughly (Page 12)

Check that the Floating Handle (Pages 5-6) is locked in a diagonal position (only applicable to models whose handles require diagonal locking) and does not have water present within it.

REMOVE ANY ADDITIONAL FLOTATION (PAGE 13, FLOTATION)

Clean the Filter Bag thoroughly as it may trap air (Page 12, CLEANING AND CHANGING THE FILTER BAG)

REMOVE ANY TRAPPED AIR (PAGE 7, CLEANER START POSITION)

GURGLING

Your cleaner may make gurgling noises when at the waterline. There are two Debris Intake Ports (Page 4, Fig. 3) on the underside (Bottom Lid Assembly) of your cleaner. When at the waterline, one of the Debris Intake Ports may be partially or entirely out of water and taking in air. This will not affect the water and oil cooled motors that are located within your cleaner for the second Debris Intake Ports is completely submersed and taking in sufficient water to keep the motors cool. In this case:

Allow your Filter Bag to continue to trap debris and particles until your cleaner no longer climbs as high at the waterline and its top Debris Intake Ports begins to submerge and the noise lessens. Remember: Your cleaner requires lateral waterline movements and therefore must reach the waterline with a portion of its scrubbing Brushes out of the water to achieve this.

If you have previously added any (combination) of the Flotation (Page 13; Fig. 17) provided into your cleaner, it is suggested that you remove the devices one-by-one until proper buoyancy is restored and the noise has lessened.

SQUEAKING

The cleaner is built from plastic, rubber and stainless steel components which may squeak as the cleaner operates. Apply non-water soluble grease or oil to component contact points [i.e. where the Wheel Tube meets the Side Plate and where the Drive Pulley meets the Bushing (Page 15; Figs. 23a-b), etc.] to assure the smooth movement of these parts and reduce squeaking.

GRINDING

Check Drive Belts and Drive Tracks (Pages 15-16) for proper tension and alignment. Adjust or replace if necessary.

CLIMBS TO WATERLINE THEN MOVES LEFT WHEN FLOATING HANDLE IS LOCKED IN ONE DIRECTION, BUT DOES NOT MOVE RIGHT WHEN HANDLE DIRECTION IS REVERSED

Should your cleaner not move left/right when at the waterline in a consistent manner throughout its cleaning cycle due to an obstruction or for an unknown reason, then your cleaner may not be able to reach and clean all areas of the pool and may remain in one or two portions of the pool while missing others.

MAKE A RECORD FOR FUTURE USE

MODEL _____

PURCHASE DATE _____

PLACE PURCHASED _____

SERIAL NUMBER _____

NOTE: Serial number can be found on the warranty card, the packing carton and your cleaner.

QUESTIONS?

CALL: 800-845-4856

EMAIL: CustomerService@AquaProducts.com

...or Logon to AquaProducts.com/Service

ADDITIONAL NOTES:

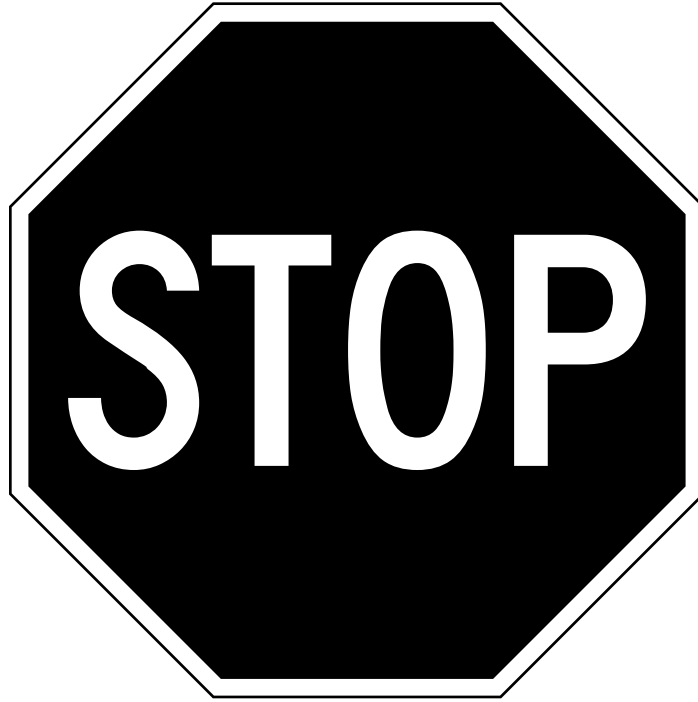

DO NOT RETURN CLEANER TO RETAILER!

**If you have a technical service issue
PLEASE REFER TO THIS MANUAL**

CALL: 800-845-4856

EMAIL: CustomerService@AquaProducts.com

...or Logon to AquaProducts.com/Service

**REMEMBER:
SIMPLE, QUICK AND EASY TECHNICAL INSTRUCTIONS FOUND HEREIN
MAY CORRECT MOST ISSUES!**